

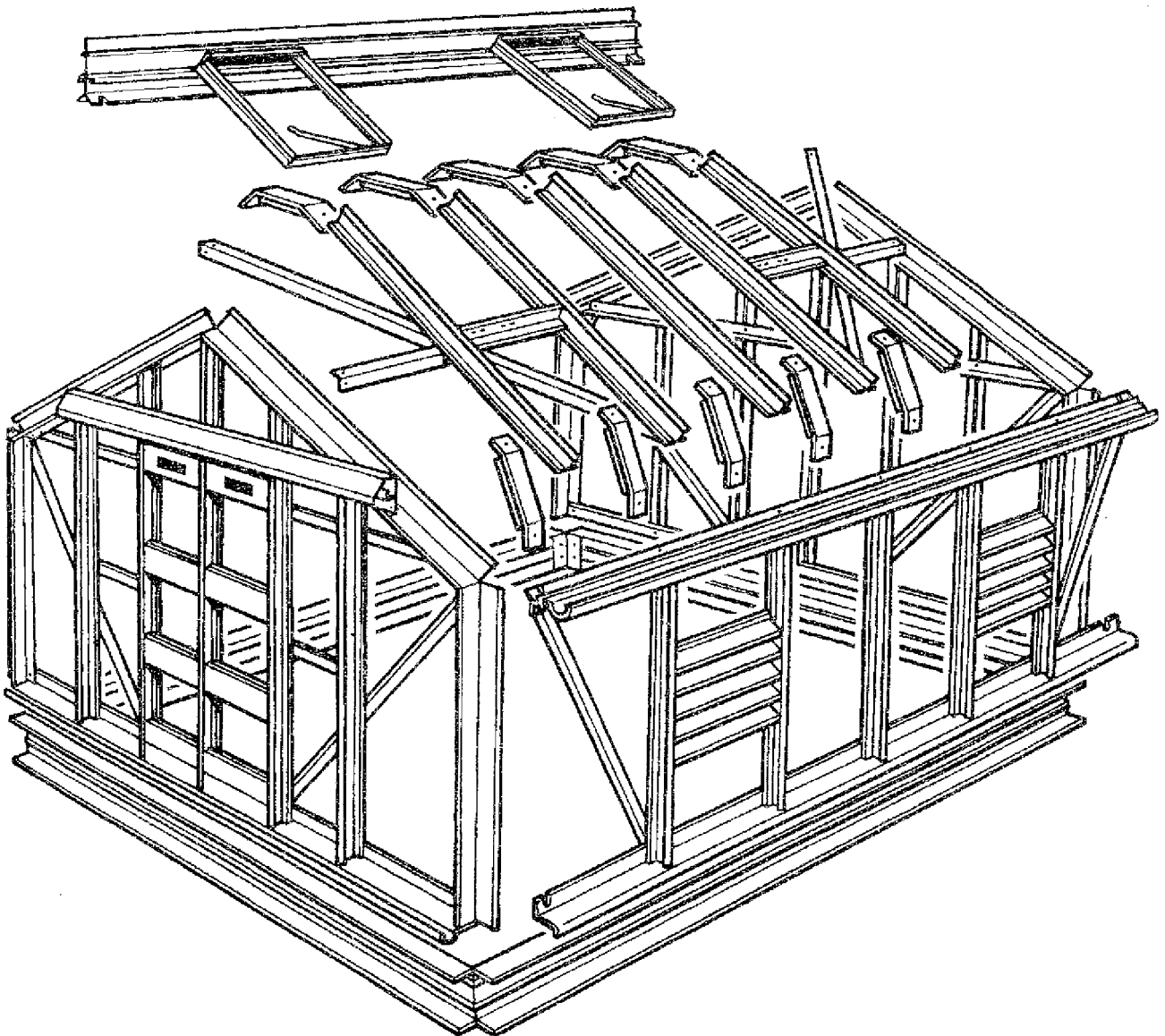

INSTRUCTIONS & ILLUSTRATIONS FOR THE
TITAN 1000



ELITE GREENHOUSES LTD

BENT SPUR ROAD, KEARSLEY, BOLTON BL4 8PD

TEL: 01204 791488 FAX: 01204 862412

enquiries@elite-greenhouses.co.uk

www.elite-greenhouses.co.uk

FITTINGS WITHIN THE KIT (NOT TO SCALE)

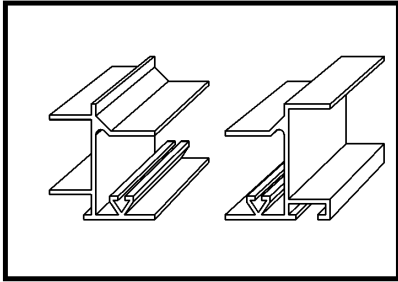

HANDED DOOR POSTS

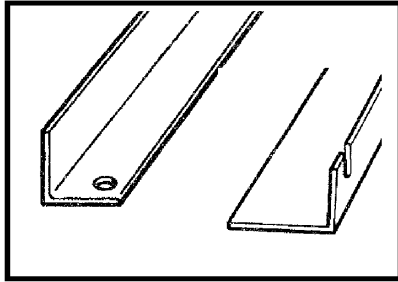

**BRACING ANGLE +
HORIZONTAL BRACE**

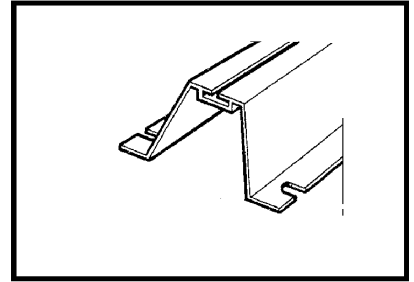

TOP HAT/ROOF BRACE

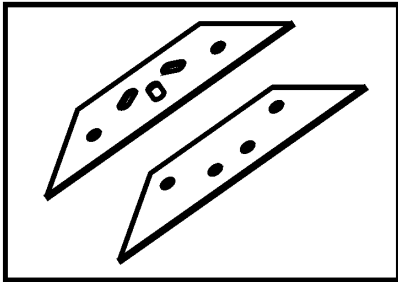

APEX & EAVE GUSSET PLATES

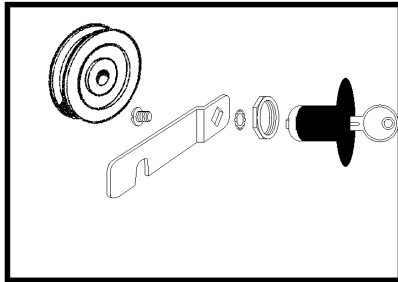

DOOR WHEEL + DOOR LOCK

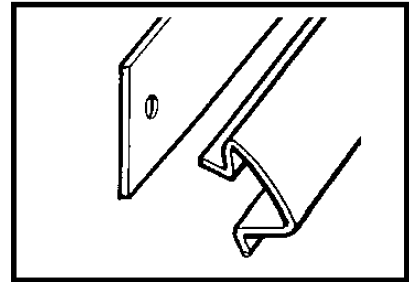

FLAT BAR & CLIP CAPPING

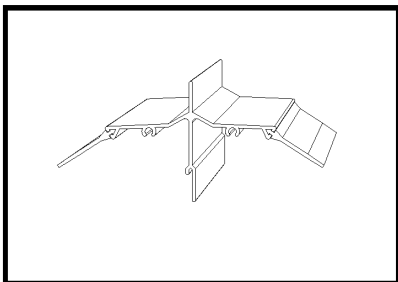

RIDGE CANOPY + SEAL

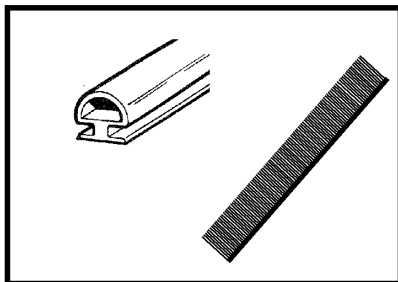

**NEOPRENE BEADING, +
DRAUGHT EXCLUDER**

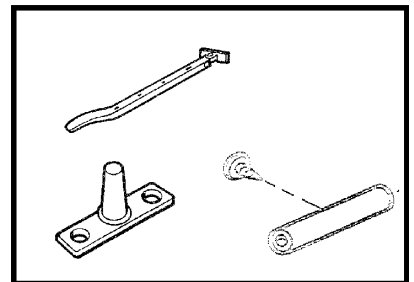

CASEMENT STAY + PINS + VENT STOPPER

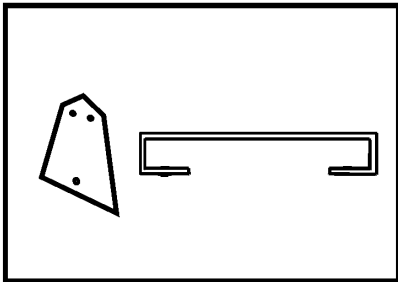

CANOPY PLATE & DOOR HANDLE

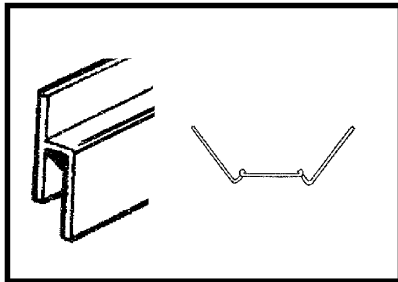

MUNTIN + WIRE CLIP

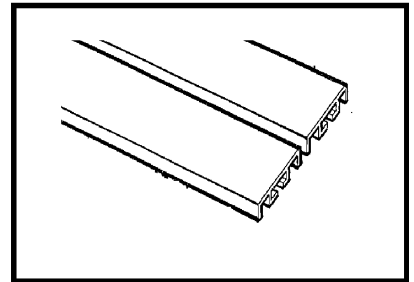

DIAMOND SHELF

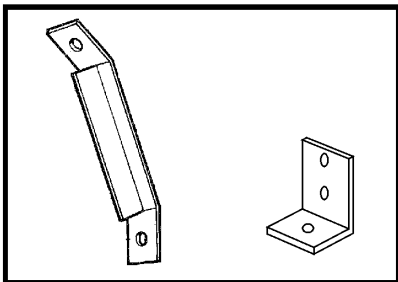

**CANTILEVER BRACE +
ANGLE BRACKET**

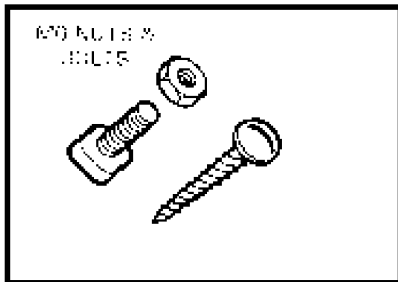

SELF TAPPING SCREWS

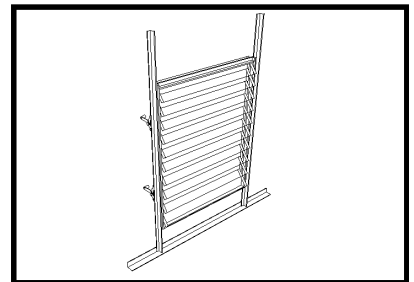

LOUVRE

COMPONENT DRAWINGS (NOT TO SCALE)

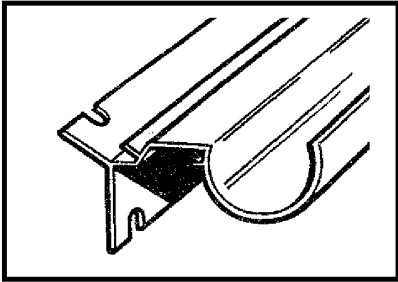

EAVES BAR/GUTTER

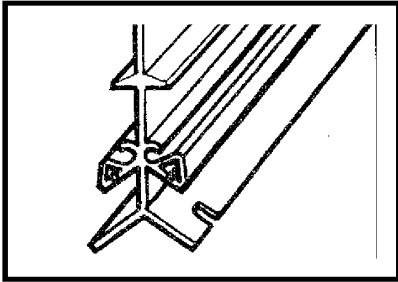

RIDGE

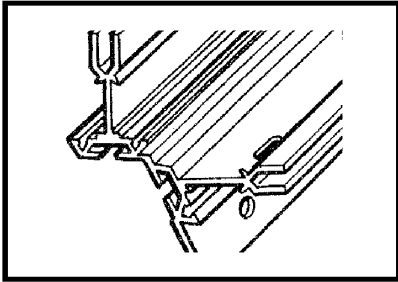

CORNER BAR

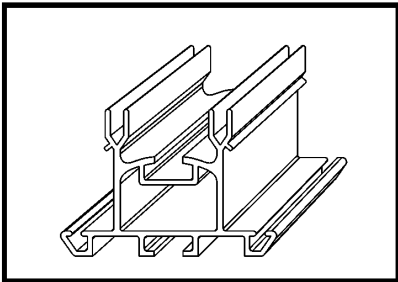

BLOCK GLAZING BAR

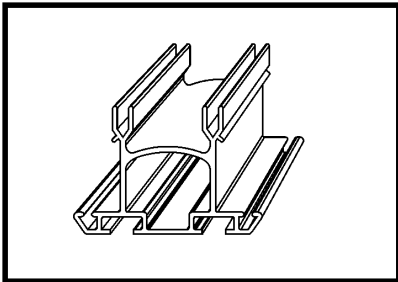

GX BLOCK GLAZING BAR

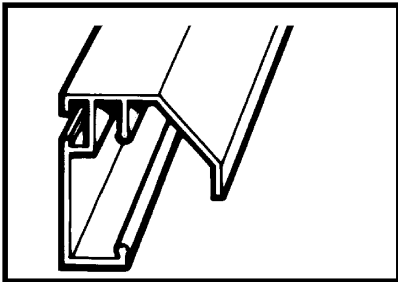

TOP DOOR TRACK

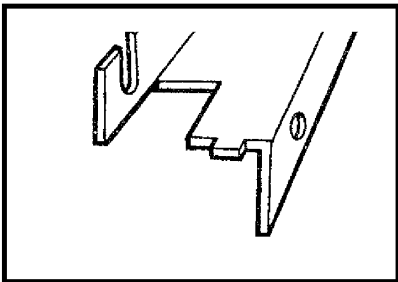

DOOR TRACK SUPPORT

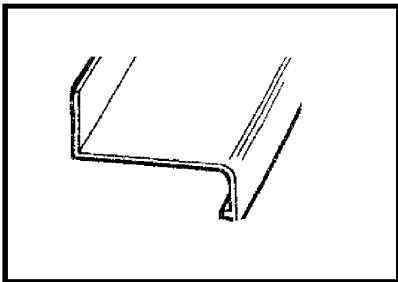

SIDE + REAR END CILL

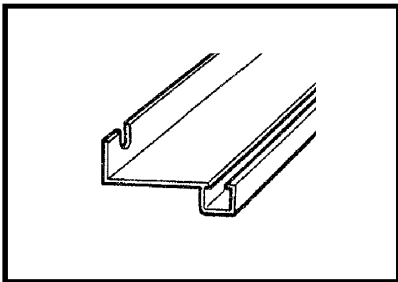

DOOR CILL

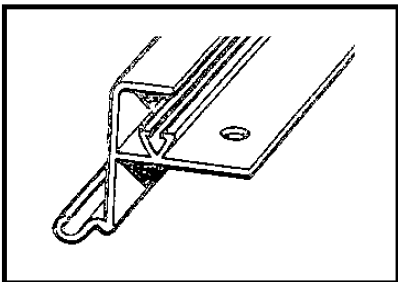

VENT TOP RAIL

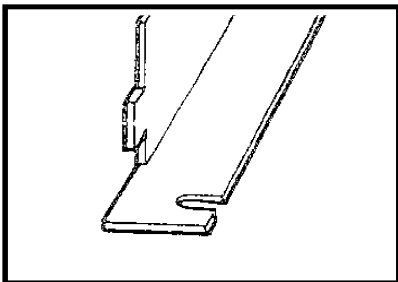

VENT SLAM BAR

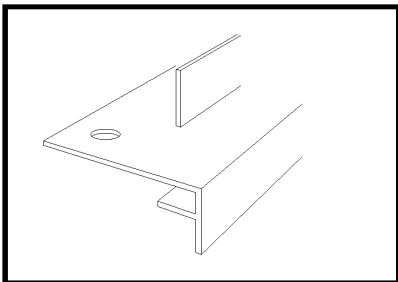

VENT BOTTOM RAIL

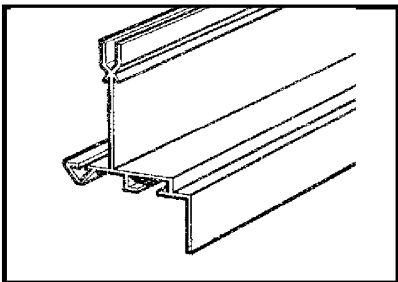

VENT SIDE RAIL

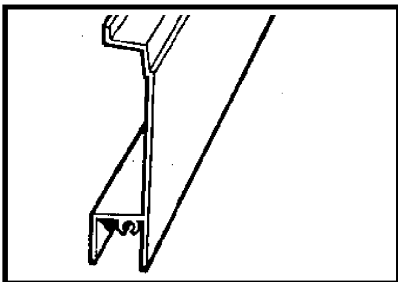

DOOR INFIL PANEL

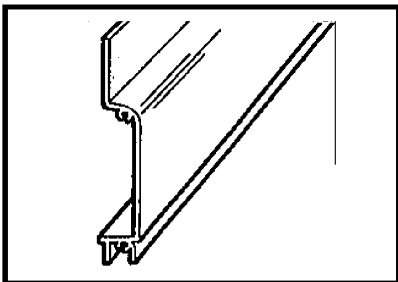

DOOR TOP/BOTTOM PANEL

PARTS LIST

			10 x 10	12 x 10	14 x 10	16 x 10	18 x 10	20 x 10
1	Ridge		1	1	1	1	1	1
2	Gutter/Eave		2	2	2	2	2	2
3	Side cill		2	2	2	2	2	2
4	Side bracing angle		4	4	6	8	8	8
5	Alloy shelf 8' long		1	1	1	1	1	1
6	Rear end horizontal angle	Taped together and marked rear end	1	1	1	1	1	1
7	Rear end cill		1	1	1	1	1	1
8	Long rear end glazing bar		1	1	1	1	1	1
9	Medium rear end glazing bar		2	2	2	2	2	2
10	Shorter rear end glazing bar		2	2	2	2	2	2
11	Diagonal angles for rear end		2	2	2	2	2	2
12	Door end cill	Taped together and marked door end	1	1	1	1	1	1
13	Medium door end glazing bar		2	2	2	2	2	2
14	Shorter door end glazing bar		2	2	2	2	2	2
15	Short door end glazing bar		1	1	1	1	1	1
16	Main door track support		1	1	1	1	1	1
17	Diagonal angles for door end		2	2	2	2	2	2
18	Upper horizontal angles end		2	2	2	2	2	2
19	Lower horizontal angles end		2	2	2	2	2	2
20	Corner bar in 2 packs of 4		8	8	8	8	8	8
21	Roof glazing bar		8	10	12	14	16	18
22	Long roof bracing angle		4	4	4	4	4	4
23	Short roof bracing angle		4	4	4	4	4	4
24	Side glazing bar		8	10	12	14	16	18
25	Vent packs in roof		2	2	4	4	6	6
26	Louvre vent for side		1	1	1	1	2	2
27	Top door track		1	1	1	1	1	1
28	Top door panels	Taped together and marked door	2	2	2	2	2	2
29	Bottom door panels		2	2	2	2	2	2
30	Intermediate door panels		3	3	3	3	3	3
31	Door posts (2 handed 2 un-handed)	Taped together	1	1	1	1	1	1
32	Tee bar cantilever		12	15	18	21	24	27
33	Glazing beading		450'	500'	550'	600'	650'	700'
34	Bag of fittings		1	1	1	1	1	1
35	Gusset plates—eaves		4	4	4	4	4	4
36	Gusset plate—ridge		2	2	2	2	2	2
37	Casement stay		2	2	4	4	6	6
38	Glass—see glazing plan at back of booklet							

ELITE GREENHOUSES BASE DIMENSIONS

For Brick, Block, Concrete or Timber

The dimensions given below may be used to locate the position for your Greenhouse or to lay corner footings if they are needed.

If a brick, concrete or timber base is laid, construct it as shown ensuring that dimensions A & B are **not exceeded** as these precise outside measurements enabling the cill to overhang the edges.

ENSURE that the base is square by measuring across the corners, only when equal is it square. Check the level using a builder's spirit level.

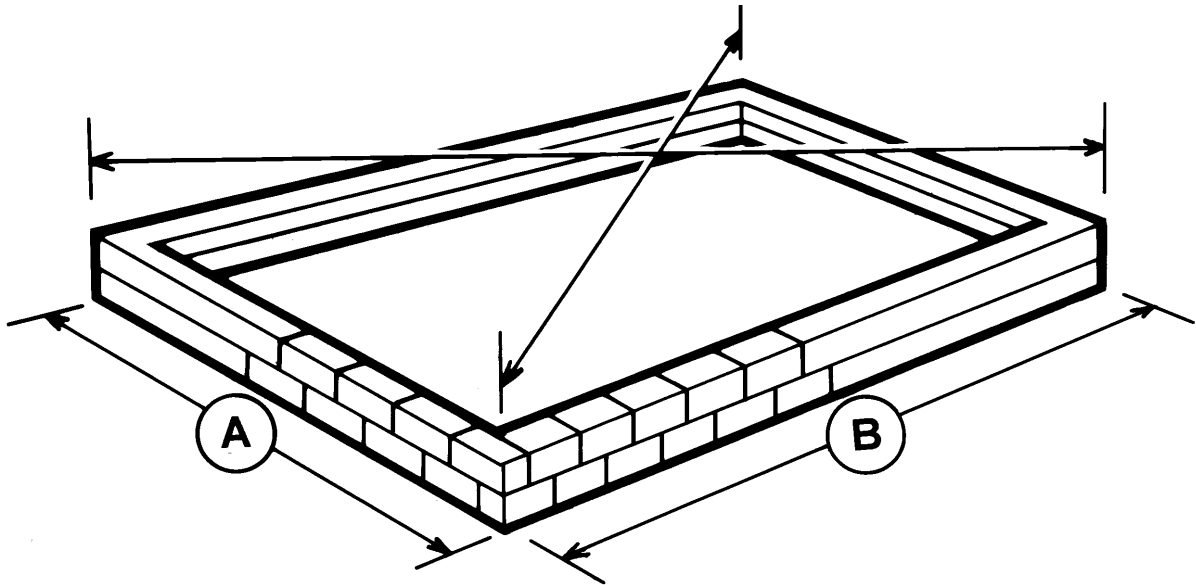

Note—If you have purchased a drop door/dwarf wall modification then you must obtain a base plan from Elite Greenhouses as the dimensions are slightly different to below.

MODEL	SIZE	A	B
	(nominal)		
TITAN 1000	10 X 10	3.195m	3.194m
	12 X 10	3.195m	3.812m
	14 X 10	3.195m	4.430m
	16 X 10	3.195m	5.048m
	18 X 10	3.195m	5.666m
	20 X 10	3.195m	6.284m

HELPFUL HINTS & ADVICE

- Please do take your time and be sure to read all instructions carefully before assembling.
- Do not assemble frame in high winds.
- The greenhouse frame should be anchored to a permanent foundation. This will not only help secure it against powerful winds but will help prevent breakage of the glass caused by the freezing and thawing process of the earth. **(Key point)**.
- When building your own brick/concrete foundations ensure that they are level and square otherwise your frame will not be correct and the glass will not fit.
- Be sure all four corners of the constructed greenhouse are square before installing glass, and do not install the glass till the greenhouse is on a permanent foundation.
- Do not place your greenhouse in vulnerable locations such as under trees, playing areas, etc.
- If using ladders/tools, ensure you are correctly trained in the safety of their use.
- Children should not play near glass greenhouses.
- REMEMBER: glass is fragile, handle with care! **(Key point)**.
- Protective clothing such as gloves, strong outer clothing and eye glasses should be worn.
- Be careful when using agricultural chemicals such as fertilisers, fungicides and insecticides etc. in the greenhouse. Do not use chemicals that are for outside use only. Always read the labels very carefully.
- Do not push or lean on the glass panels.
- Use extra care when moving heavy or awkward objects such as tables, poles, internal frames etc. within or near the greenhouse.
- Be aware of the increased temperature in the greenhouse on a sunny day.
- Do not keep pets or other animals in a greenhouse.
- When cleaning glass do not exert too much pressure.
- If your greenhouse is a painted one there are a few 1/8" holes in the end of the bars. These are jig holes for painting and have no bearing on construction. **(Key point)**.
- Powder coated packages are wrapped in polythene tubing – please be careful when opening. e.g. Do not run a knife down the sides as you can scratch the paintwork.
- **WHEN CONSTRUCTING A PAINTED MODEL PLEASE TAKE CARE NOT TO DAMAGE THE FINISH BY WORKING ON CONCRETE OR PATIOS.**

N.B. This plan covers the entire Titan 1000 range. The only difference between a 12ft long and a 20ft long for example are a few extra pieces of alloy, glass, nuts and bolts etc. The construction of the sub-frame assemblies is the same but for the purposes of this booklet we have used the 12x10 model as the benchmark. Therefore only one plan is needed.

We reserve the right to alter and improve our products.

DETAILED ASSEMBLY INSTRUCTIONS

The contents of this carton are divided into the different frame assemblies that collectively make up the completed unit.

It is recommended that each framework assembly is **fully** completed before moving onto the next.

The frames to be constructed are as follows:

1. Side frame - two off
2. Rear gable – one off
3. Door gable – one off
4. Roof vent
 - 10 x 10 = 2 frames
 - 12 x 10 = 2 frames
 - 14 x 10 = 4 frames
 - 16 x 10 = 4 frames
 - 18 x 10 = 6 frames
 - 20 x 10 = 6 frames
5. Door – two off at 457mm wide.

WE CAN NOW COMMENCE WITH THE ASSEMBLY

If you are building your own brick base please refer to the dimensions in this booklet (labelled “Elite Greenhouse Base Dimensions”). It is recommended that a concrete footing is built prior to the laying of the bricks/blocks. Dwarf wall/dropped door modifications require a manufacturers base plan.

Excavate a trench about 9” wide and dig down to hard earth or clay. Fill the trench with 4” approx. of hard-core and cover with a concrete mix, ensuring that the final concrete is level. You can now lay the bricks/blocks on top of this to the desired height, usually 2 courses of standard brick above ground level.

N.B. All base work must be level and square and built to the precise outside measurements. **(Key point).**

SIDE FRAME ASSEMBLY

From the pack you require:

- Pack of side bars marked "side bars"
- Pack of gutters and cills marked "side"
- Pack of angles marked "side"

From the pack of fittings you need: nuts and bolts, glazing beading.

Procedure: For the point of this plan we have used a 12' x 10' side as an illustration, the procedure is identical for a 10' x 10' and 20' x 10' apart from, you need more or less side bars, nuts and bolts, glazing beading and longer or shorter gutters and cill. **(Key point)**.

If you have purchased a partition with your greenhouse you will have 2 less roof and 2 less side bars. These are replaced with an extra set of corner bars. You must decide where the partition is to be situated and at that point leave out one side bar on each of the side frames. **(Key point)**. The partition is constructed when the greenhouse is fully erected prior to glazing. Full details of this procedure given later in the booklet, but for the time being do nothing apart from the omission of the side bar. **If you have not purchased a partition disregard this and future notes relating thereto.**

You need for each side frame: 1 gutter/eaves, 1 cill, 2 diagonal angles and 5 side bars. (N.B. For the longer sides you have 4 diagonal angles per frame).

Before assembling any sections slide the required number of bolts into the glazing bars as detailed in the relevant part of the booklet.

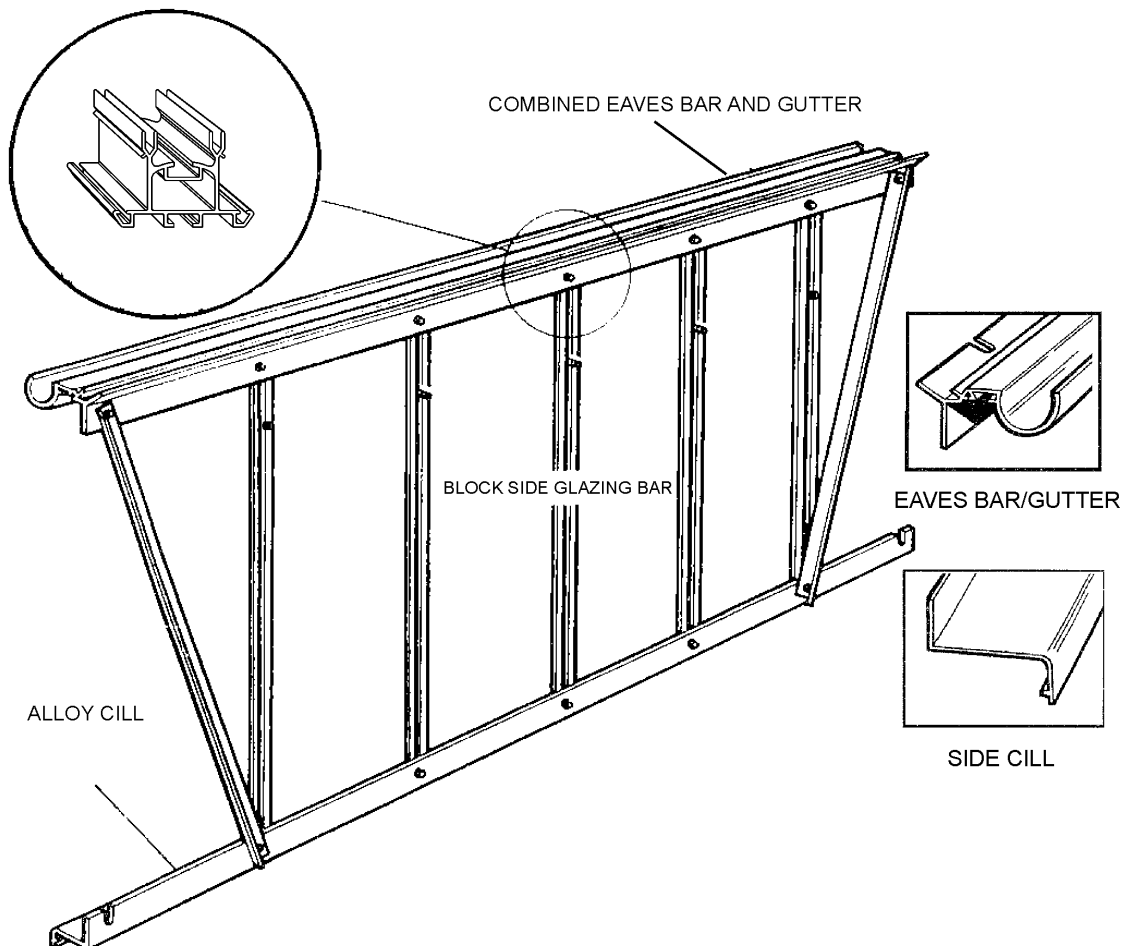

1. Slide the glazing beading into each side bar taking care not to stretch the material. Trim off any surplus level with the ends of the glazing bar. **(Key point)**.

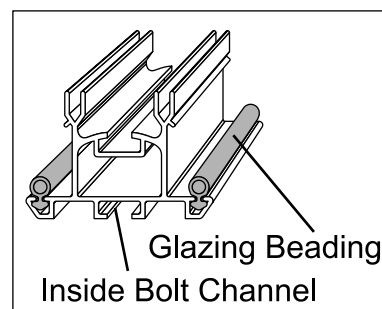

2. Lay the 9 components on the floor as though you were standing inside the greenhouse i.e with the gutter and cill facing downwards and the bolt slot of the glazing bar upwards. **(Key point)**. (Beading channel downwards).

3. Slide 3 bolts into each glazing bar (insert an extra two bolts into the bars that the louvre vent will attach to). **(Key point)**. The middle bolt of the three will be used later to attach the cantilever tee bars. Fix the combined eaves and gutter bars to the glazing bars by pushing the bolt previously inserted through the holes in the lower flange of the eave and secure with a nut. Ensure that the glazing bar is pushed up under the gutter and is tight up against the inside shoulder of the eave. **(Key point)**. Do the same with the rest of the glazing bars.



BEWARE OF SHARP EDGES!

4. Fix the cill in a similar way to 3 above but start with the middle glazing bars and work outwards. Before fixing the nut to the cill, read points 5 + 6.

5. If you are fitting the greenhouse onto a hard standing (brick, concrete etc.) then before attaching the nut to the bottom bolt, fit the angle brackets as shown to each glazing bar. Angle bracket **behind** diagonal angle where applicable.

6. The 2 outer glazing bars have the diagonal angle ties bolted to them. Before attaching the nuts, place the tie bar over the bolts so that they point outwards towards the end of the eaves bar. They must be arranged so that the internal part of the angle, in each case faces towards the middle of the house. N.B. For the 10' and 12' models there are 2 angle ties per side, for the 14' there are 3 and for the 16', 18' and 20' models there are 4 per side: the extra braces are centrally positioned (diagonally like the 2 end ones) for additional strength. **(Key point)**.

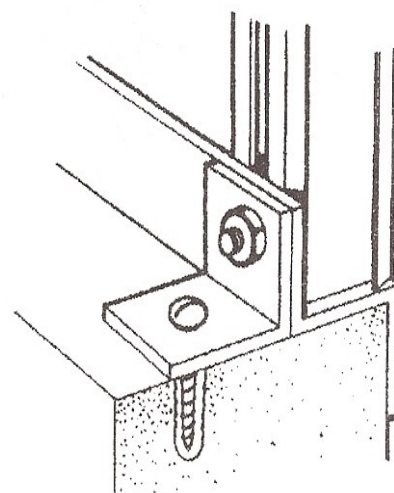

7. Ensure that the glazing bars are tight up against the cill and inside shoulder of the eave, tighten all nuts. The nuts and bolts are aluminium and only require one turn with the spanner after first finger tip tightening. **(Key point)**.

8. Do exactly the same with the other side frame.

9. If you intend to install louvres or shelf/staging to either of the 2 sides just built, they are supplied with ½ head bolts so can be fitted retrospectively.

WELL DONE! YOU HAVE SUCCESSFULLY COMPLETED THE 2 SIDE FRAMES!

REAR END ASSEMBLY

For the construction of this frame you require from the main box: 1 pack of corner bars marked “corner bars” and 1 rear end pack marked “rear end”.

From the pack of fittings you need: nuts and bolts, glazing beading and gusset plates (1 large – ridge plate, 2 small – eave plates)

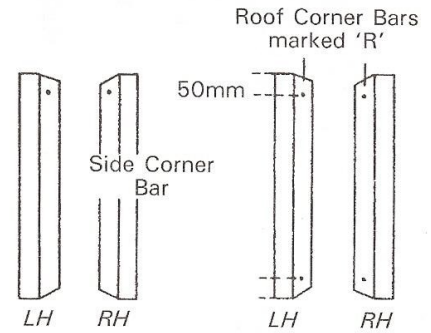

PROCEDURE

1. Starting with the pack of corner bars split the tape holding them together and first identify the 2 roof bars from the 2 side bars. The side bars have one hole and 1 mitre, both at one end. The other end has no hole and is square cut. They are also shorter in length (1345mm) than the roof. The roof bars have 4 holes in the flange and are mitred at both ends and in addition have a letter ‘R’ written at the apex.

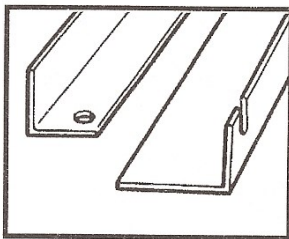

BRACING ANGLE HORIZONTAL BRACING ANGLE

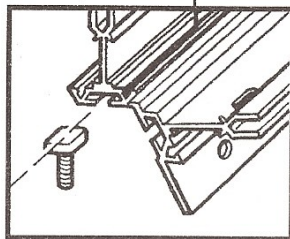

CORNER BAR

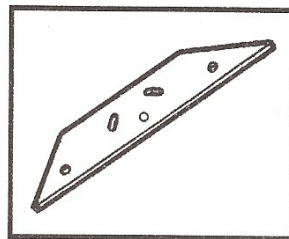

RIDGE GUSSET PLATE

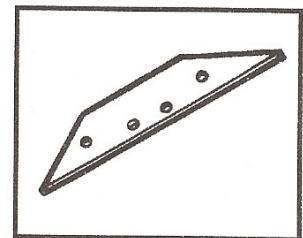

EAVE GUSSET PLATE

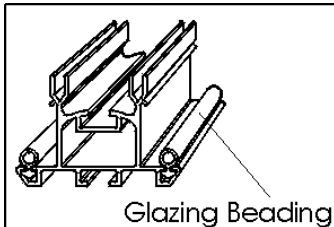

Glazing Beading

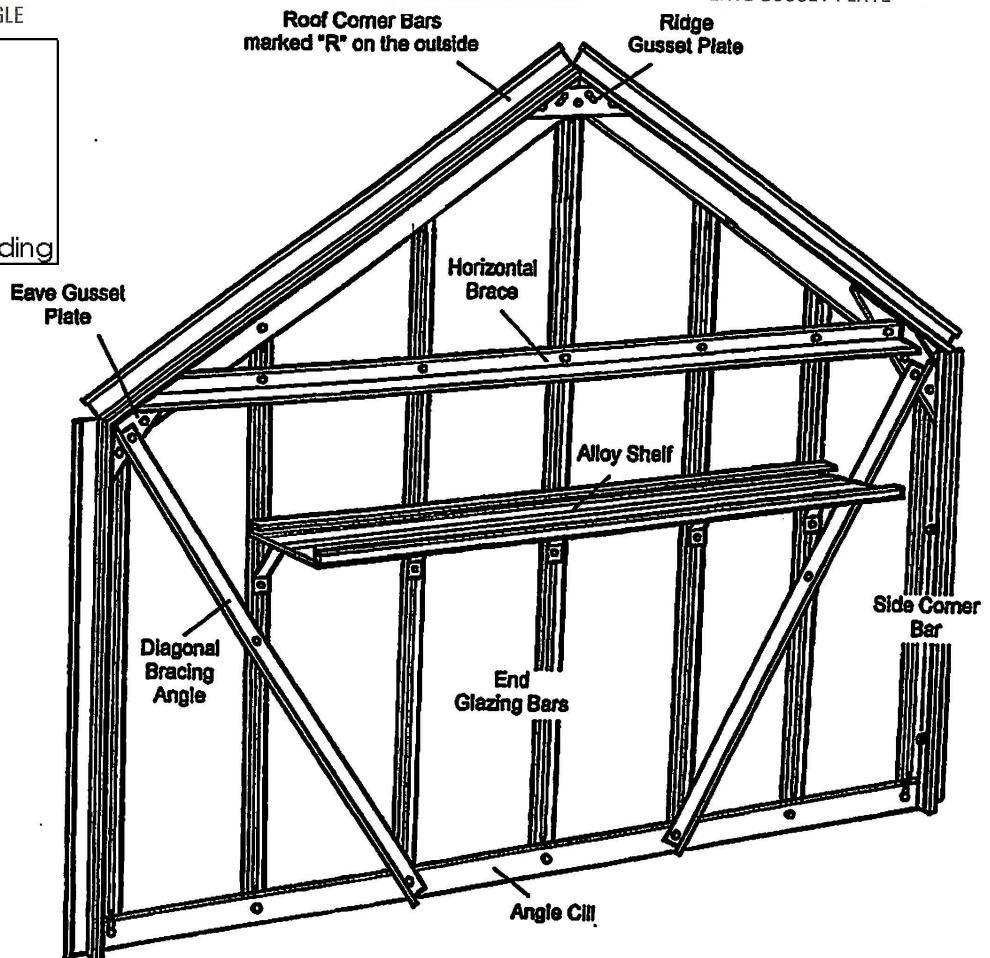

on the **outside** of the bar and are longer in length (1855mm). N.B. If your greenhouse is a painted one, the roof corner bars will not be marked with a letter 'R'. They can be identified from the side bars as outlined above. **(Key point)**.

The bars are also handed so you must identify the left and right hand. Standing up, hold one side bar vertically in your left hand and the other in your right, rotate the bars so that the 2 bolt slots are facing in towards you, with the mitres at the top (inside view). Viewed this way the 2 mitres should run down to each other. The roof bars can be handed similarly, keeping the bolt slots facing inwards and the letter 'R' to the top. (With a painted model, the top can be identified by observing the 4 holes in the flange. The two holes nearest the end are at 50mm and 33mm centres, the 50mm end is the top i.e. nearest the ridge). On the outside you can identify them by ensuring that the 'R's (indicating ridge) are at the top, the mitres will then run into each other.

2. Slide the glazing beading into the 5 vertical glazing bars and the 4 corner bars, taking care not to stretch the material. Trim off any surplus level with the end of the bars. N.B. the corner bars have 3 grooves to receive the glazing bead, do not put any in the middle one. **(Key point)**. (Unless this gable will become an internal partition.)

3. Lay out the components of the frame on the ground as though you were standing on the inside i.e. with the bolt slot uppermost and beading channel downwards. Ensure that, having correctly identified the roof from the side corner bars, left and right hands (see previous text) you have the roof bars with the letter 'R' (indicating ridge) at the top on the outside, i.e. towards the ground. **(Key point)**.

4. Slide 3 bolts into the alternative bolt slot of each roof corner bar bolt slots (see diagram for alternative and facing bolt slot description on page 13); leave 1 at the top, 1 at the bottom and one in the middle. Put a nut on and lightly tighten, leaving them approx. 2" from the end of each bar. These will be used later in the general assembly. For the side corner bar you need only insert 2 extra bolts into the alternative bolt slots, 1 top and 1 bottom.

5. Starting at the apex (2 roof corner bars opposite each other marked 'R') slide 1 bolt into the **facing bolt slot** i.e. the one that is facing upwards and is set at 90° to the alternative bolt slots – 4 above. **(Key point)**.

6. Place the ridge gusset plate (larger of the 2 types) over the bolt, slide the plate left or right until the slotted hole in the plate lines up with the locating hole in the flange nearest to the end of the corner bar. Put nuts on both bolts i.e. flange and plate and leave the nut loose. **(Key point)**.

7. Do exactly the same with the other roof corner bar ensuring that the two bars are pressed tight up together behind the ridge gusset plate.

8. At this stage you do not need to use the middle, 5th hole in the gusset plate.

9. Now moving to the eave gusset assembly, slide one bolt into the facing bolt slot (the one that is facing upwards and is at 90° see 4 above). Place the eave gusset plate (smaller of the 2 types) onto the bolt and move it left or right until the next hole in the plate lines up with the locating hole in the top of the side corner bar. Place a bolt through the hole and put a nut on finger tip tight only. **(Key point)**. Put a nut on the bottom bolt and leave loose.

10. Do the same with the other part of the same eave gusset plate, ensuring that both corner bars are tight up against each other behind the eave plate.

Details of Ridge Gusset Plate on Roof

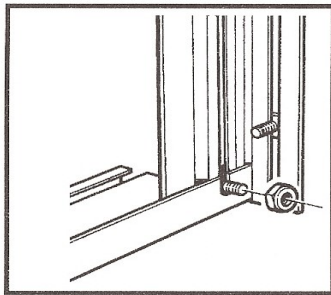
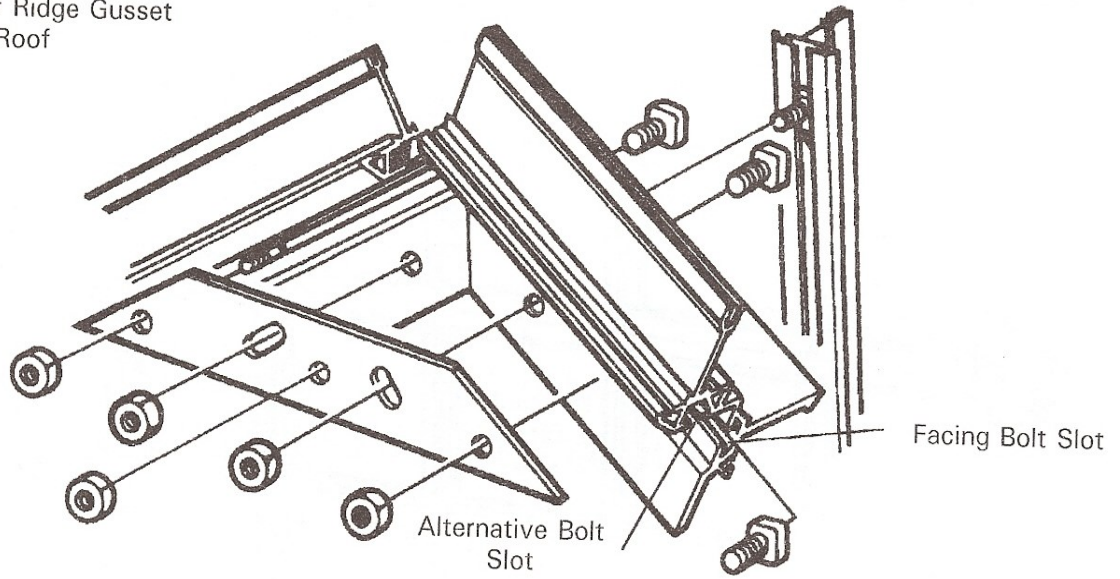

BOTTOM CILL/CORNER BAR

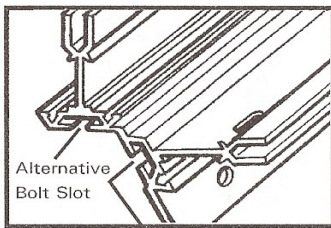

Alternative Bolt Slot

Facing Bolt Slot

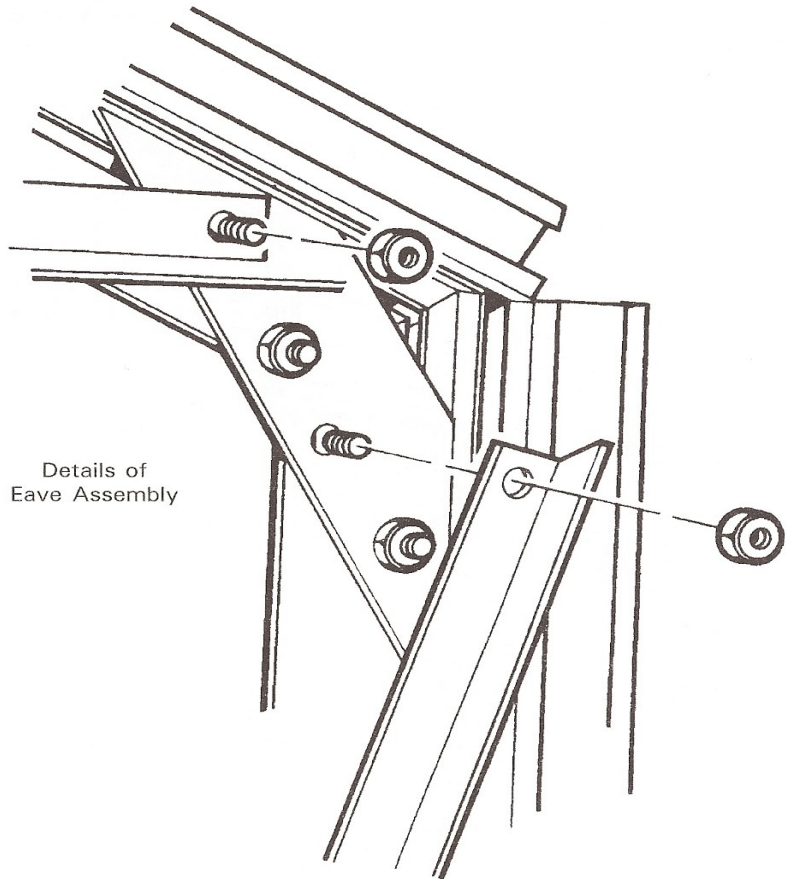

Details of Eave Assembly

11. Repeat steps 9 and 10 at the other corner with another eave gusset plate.
12. Attach the bottom cill to the left and right hand side corner bars by inserting a bolt into the facing slot. Line the bolts up with the 2 slotted holes at the end of the cill, put nuts on and tighten up ensuring that the corner bars are pushed right down into the angle of the cill. **(Key point)**.
13. You can now attach the 5 vertical glazing bars to the bottom cill in a similar manner to above. The longer bar to the middle hole and the shorter ones to the outer holes. Before attaching the nuts of the intermediate bar, place the diagonal angles (1635mm long) onto the bottom bolt and put a nut on finger tip tight only. Attach the other end of the angle brace to the 2nd bolt up from the bottom of the eave gusset plate. **(Key point)**. Put on the nut and leave loose. **(Key point)**. Do the same with the other diagonal brace. If fitting to hard standing, repeat the installation instruction for the angle brackets at the bottom of each glazing bar.
14. Moving to the top of the greenhouse, insert 5 bolts into the shorter two glazing bars and 4 bolts into the intermediate two glazing bars and the longer middle glazing bar. The last bolt inserted in each bar will attach to the pre-fabricated holes in the roof corner bar.
15. Now you can attach the long horizontal brace to the **top bolts** of the eave gusset plates. The angle should be facing upwards, put the nuts on and finger tip tighten.
16. You can now attach the 5 vertical glazing bars to the roof/corner bars (long middle bar to the ridge gusset plate). Slide the last bolt in each bar you inserted in 14 above to the top of each bar and insert them through the holes in the flange of the roof corner bar, place the nuts on and finger tip tighten.
17. Now attach the horizontal brace to the 4 upright glazing bars utilising the bolts you inserted in 14 above. Put the nuts on finger tip tight. **(Key point)**. You should now have two bolts left in each bar. They are used for the shelf.
18. It is easier to attach the shelf to the gable during initial construction so please observe the diagram on page 11 and refer to the plan with the shelf brackets.
19. The rear end is now almost complete. Before tightening up all the nuts check the corners to ensure they are tightly up against each other and that all the vertical bars are tight up against the angle of the rear end cill and corner bar. Tighten all nuts, the rear end is now complete.
20. Attach the diagonal angles to the 2 shorter glazing bars. Slide the bottom bolt previously inserted in 14 above to the middle of the bar. Place the shelf clamp over the bolt and tighten so that the diagonal angle is clamped to the glazing bar. **(Key point)**. Tighten all nuts, the rear end is now complete.

DOUBLE DOOR END ASSEMBLY

For the construction of this frame you require from the box:

1 pack of corner bars – marked “corner bars”

1 door end pack – marked “door end”

From the main bag of fittings you need: nuts and bolts, glazing beading and gusset plates – 1 large (ridge plate), 2 small (eave plates)

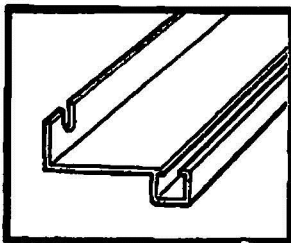
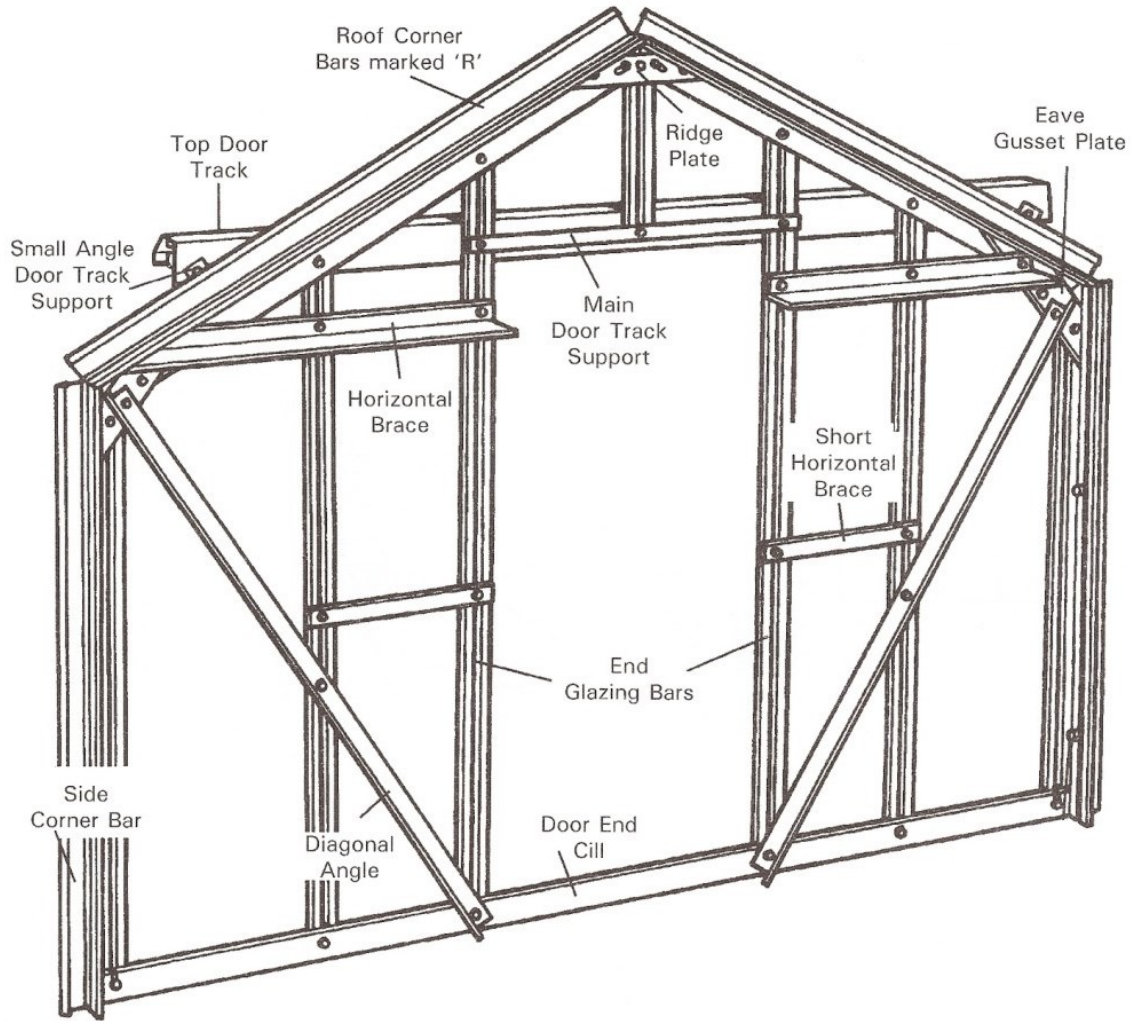

DOOR END CILL

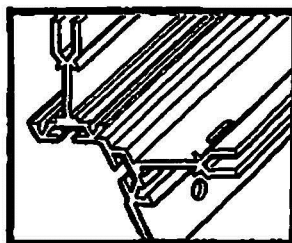

CORNER BAR

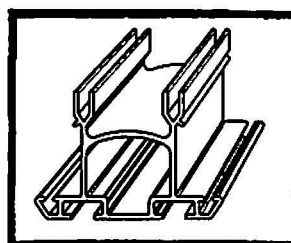

GX BLOCK GLAZING BAR

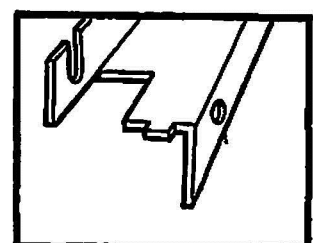

DOOR TRACK SUPPORT

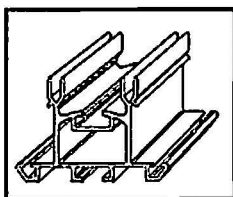

BLOCK GLAZING BAR

PROCEDURE

The format of the door end is identical to the rear end assembly up to and including step 13 so please refer to those items in the previous pages.

1. For step 14. Slide 4 bolts into each short vertical glazing bar, except short glazing bar over the door. Do nothing but bead the small bar over the door.
2. The long door end glazing bars have 2 bolt channels. When in position, slide 3 bolts into the channel closest to the corner bar and 2 bolts into the channel closest to the door opening.
3. The long horizontal brace is replaced by 2 shorter ones that attach to the upper bolt of the gusset plate but stop at the longer middle bars to facilitate the doorway, (fix to the bolt slot nearest the corner bar).
4. There are 2 additional short horizontal braces that attach to the 2 shorter vertical glazing bars at a point immediately above where the diagonal angle bolts to the bar, then to the longer intermediate bars horizontally along which thus ensures the doorway remains well braced and perpendicular.

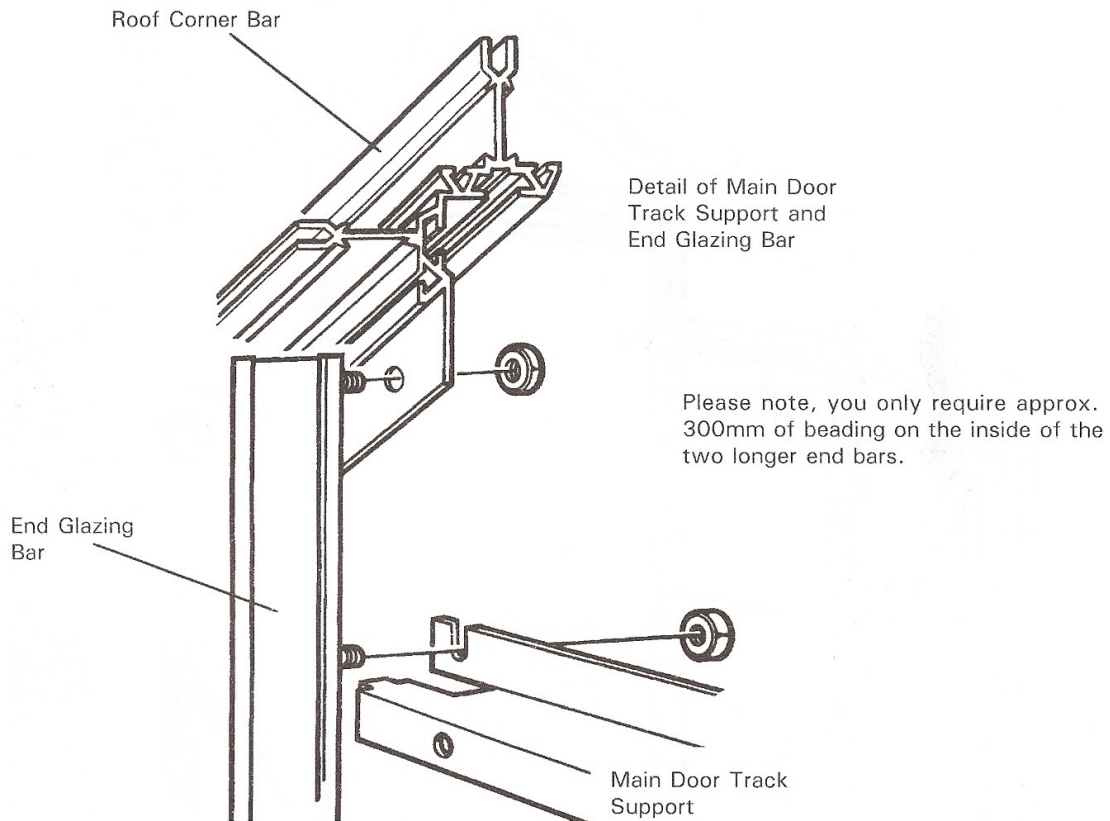

5. The **main door track** support can now be fitted at a point half way between the horizontal angle and the corner bar. It is important to note that the 2 slotted holes at the extremes of this section are facing **upwards** and not **downwards**. (**Key point**). Do not fit the top door track or the short glazing bar above the door opening at this stage.

6. Check that all joints are tight and all braces are in position, and then tighten up all nuts. The end is now complete.

You have now completed the 4 main frames of the structure which can now be joined together. You need not do this procedure on the base but any flat surface near the greenhouse site. If your base is prepared however, you can carry out the assembly there to save lifting it on later. **But before this we construct the vents and doors.**

ROOF VENT ASSEMBLY

The roof vent pack has 5 pieces of aluminium: and from the main box of fittings you require
6' of glazing beading
4 nuts and bolts
2 casement stay pins
1 casement stay
6 M4 stainless steel nuts and bolts

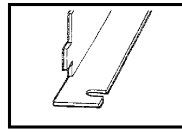

VENT SLAM BAR
(FITTED TO ROOF LATER IN ASSEMBLY)

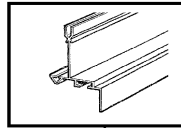

VENT SIDE RAIL

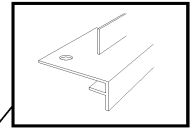

VENT BOTTOM RAIL

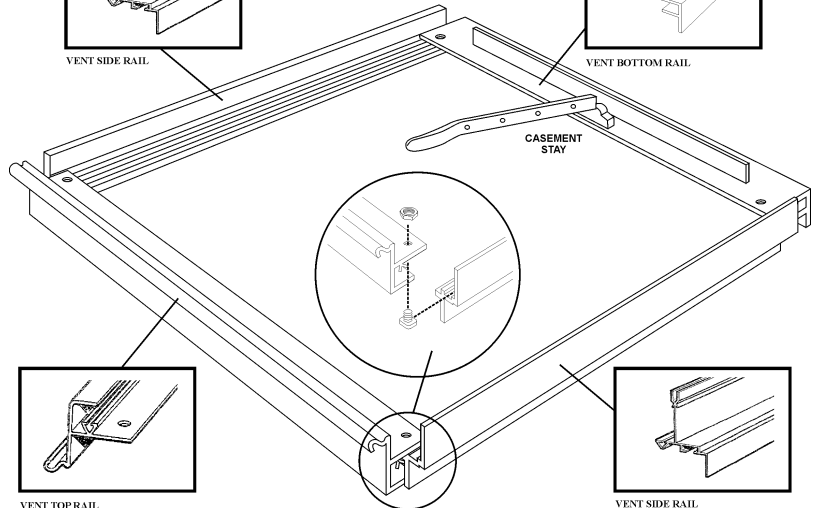

PROCEDURE:

1. Identify the slam bar and attach the 2 stay pins to the outer side of the angle using the M4 stainless steel nuts and bolts.
2. Lay the 4 edge pieces of the vent on a level surface as though you were on the inside of the vent (with the bolt slots of the side bars uppermost and the 'v' slots of the bottom rail uppermost. The top rail is arranged in such a way that the squared off end is to the bottom and the hooked hinge uppermost).
3. Slide the glazing beading into the slots in the side and top rails and trim to suit.
4. Insert a bolt into each end of the side rail bolt slots, put these bolts through the holes in the top and bottom rails, add nuts and lightly tighten. Check that all joints are secure and that the vent is square, and then tighten up the nuts.
5. Fit the casement stay using the M4 stainless steel nuts and bolts, putting the bolts through the holes in the saddle of the stay and through the 2 elongated holes in the bottom rail. Hold the nuts in place and tighten the bolts with a screwdriver.

Do the same with the other vents.

The vents can be positioned onto the ridge after general assembly by sliding them along the ridge from the end and locating them to the desired position.

Do not fit the vent at this stage.

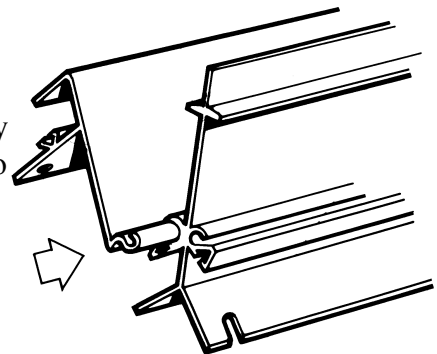

DOUBLE DOOR FRAME ASSEMBLY

Each Door consists of:

- 1 unhandled door post
- 1 handed door post (handed post for left door is different profile to the handed right hand door post)
- 3 infill panels (1 with pre fabricated lock hole) for lock barrel
- 1 top and bottom door panels
- 3 panels of glass which must be fitted during door assembly

It is not possible to fit glass after the door is built

From the main bag of fittings you require:

- door
- 2 door wheels
- 1 clip on nylon door skid (this might already be fitted to the bottom door panel)
- 2 lengths of black brush draught excluder with PVC carrier
- Door lock, self tapping screws and spring washers
- 12' glazing beading
- Door handles
- 3 PVC Glass strips

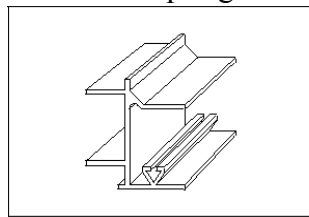

HANDED DOOR POST
RIGHT HAND DOOR

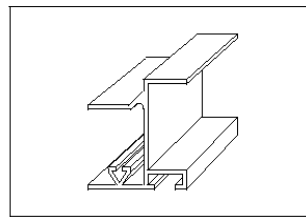

HANDED DOOR POST
LEFT HAND DOOR

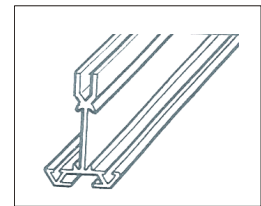

UNHANDLED
DOOR POST

Left hand Door (viewed from outside)

Identify the correct door posts. The handed door post for the left hand door has a bolt channel, whereas the handed door post for the right hand door post does not. **(Key point).**

1. Place one unhandled post and the handed post for left hand door on a level surface roughly two feet apart with the bolt slots facing downwards. (Unhandled door post on the left, handed door post on the right). The top of each side post has two screw holes in it, the bottom has three. **(Key point).** Slide the glazing beading into the groove of each bar i.e. only one length of glazing beading per bar.
2. Place the top, bottom and 3 infill panels in position as shown by the position of the screw holes in the side pieces and the panels. The top panel has the greenhouse name on it. The bottom panel has the edge for the door skid to fit on. The lower infill panel locks on to the bottom panel. The infill panel for the left hand door **does not** have a pre fabricated hole for the lock barrel.
3. Fix the left hand door post to the door panels by screwing through the door side pieces into the holes provided in the edge of the panels with the self tapping screws. The screws will go in more easily and with out danger of trying to go crooked if you can put a small amount of grease on the screw before assembling the doors. Alternatively, you could insert the screws into the screw eyes of the door panels before assembling the door; this would have the effect of pre-self tapping the panels prior to assembly, making assembly easier.
4. **GLASS MUST BE FITTED TO EACH DOOR BEFORE THE 2ND DOOR POST IS FITTED—(KEY POINT)**

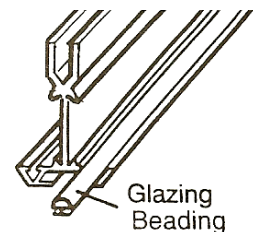

5. Before fitting the unhandled door post, offer the glass panels to the door (see glazing plan in booklet for glass size guide on door), slide them in from the side. Carefully attach the unhandled door post in the same way as before, ensuring the glass is sitting in the correct position (sitting on the beading channels of the door posts) before tightening the screws.
6. Make sure all angles are square and tighten all screws. Now insert 2 glazing clips to the glass on the unhandled door post.
The other side of the door is clipped using a P.V.C. glass strip (or clip cap). Cut the strip to the correct length and push into the cavity between the glass and the handed door post. The cap when fitted acts as a wedge to prevent movement of the glass. Metal clips are not fitted to this bar.
7. Fix each door wheel into position by pushing the bolt provided through the centre of the wheel and then through the hole in the top door panel from underneath (i.e. from the inside of the door). Put the washer over the bolt and secure with the nut provided, tightening until there is no movement on the bolt. The nuts are lock-nuts and are harder to put on than normal nuts in general assembly. The wheel will revolve freely because it has ball bearings in it. **The wheel has a collar protruding from the centre, this collar goes against the inside face of the top door panel. (See picture below).**
8. Slip the nylon door skids on each of the bottom panels. This may already have been done prior to delivery. After fitting the doors (see later in the booklet), you may need to lower the door skid so that it engages with the bottom door cill to allow smooth movement of the door. Lower the skid on each door and insert a self tapping screw at each end of the skid to reinforce the position.
9. Build the right hand door using the remaining handed and unhandled door post. Viewed from the outside, the handed door post will be on the left of the door, while the unhandled door post will be on the right. At this point you must decide the height you would like your door lock. The hole to take the door lock is on the left hand side of the infill panel. You can decide to fit this panel to the 2nd or 3rd panel down. **Make sure you fit the glass before final fixing of the door.** See glazing plan towards the back of this booklet. Fit the lock after the doors are in position on the greenhouse.
10. Thread the stainless steel backed brush extruder into the PVC carrier. This may already have been done prior to delivery.

11. Turn the doors over and insert the black brush draught excluder in the groove (bolt slot) in the unhandled door posts. Insert a nut and bolt at the bottom of each unhandled door post and tighten so that the brush will not slip down when the door is in its upright position. Cut off the surplus brush and carrier at the top of the bar.

12. Do not fit the door to the gable at this stage – wait until the structure is fully assembled prior to glazing.

13. Door handles can now be fitted.

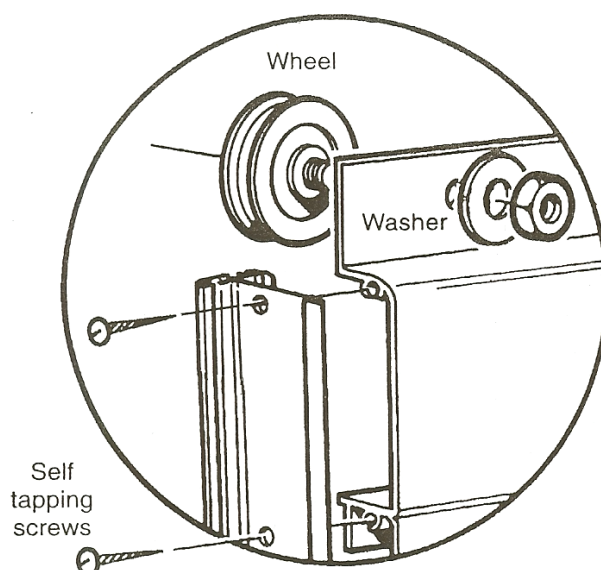

DOOR FRAME ASSEMBLY

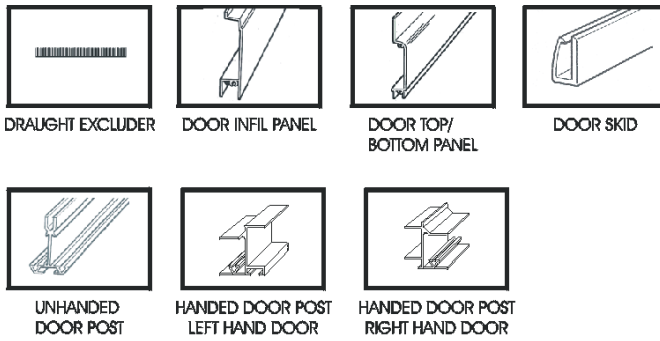

FITTING THE DOOR HANDLES

The handles are fitted to the infill panel on each door (choose between 1st or 2nd panel down). Position the handle centrally, and mark the hole position. Drill 7mm diameter holes (2 holes per door), then fit the handles, and secure with a nut and bolt.

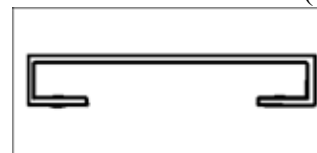

ASSEMBLY OF THE GREENHOUSE UNIT

PROCEDURE

1. With the help of a willing assistant, stand up the rear gable and one of the sides. Standing on the inside of the structure with the gutter facing away from you, insert the eave/gutter bar into the gap between the corner bars, so that the inside flanges of the gutter which form the angle of roof and side line up with the bolt slots in the corner bars. **(Key point).**
2. Undo the nuts holding the 2 bolts you inserted in the corner bars alternative bolt slot and slide them into the slotted holes in the flanges. Put a nut on the top bolt, put the side diagonal brace on the bottom bolt and then the nut and tighten up.
3. The bottom cill of the sides attaches to the corner bars in a similar way. Undo the nuts and bolts inserted in the gable end assembly, move the cill under the corner bar so that the elongated hole in the vertical flange of the side cill lines up with the bolt slot in the corner bar. Move the bolts down the slot into the slotted hole, put a nut on and tighten up, ensuring that the corner bar is pushed right down into the angle of the cill.

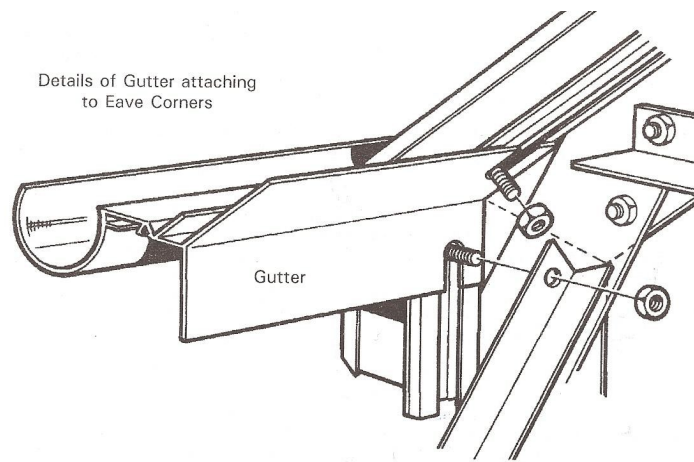

4. Now stand up the door end assembly and repeat the above procedure.

5. Stand up the other side frame and repeat the operation outlined in 1, 2 and 3 above at both corners.

6. The ridge bar is fitted next, but first you must thread the glazing beading into the 2 grooves on the ridge. **(Key point)**. Lift the ridge bar up to the apex and standing on a pair of sturdy and safely placed stepladders push the ridge into the small gap between the roof corners so that the 2 flanges which form the angle of roof are tight up against the inside edge of the corner bars. The vertical part of the ridge is outside and pointing skywards. Undo the nuts and bolts previously inserted during gable end assembly and push them upwards into the slotted holes of the ridge. Tighten the nuts.

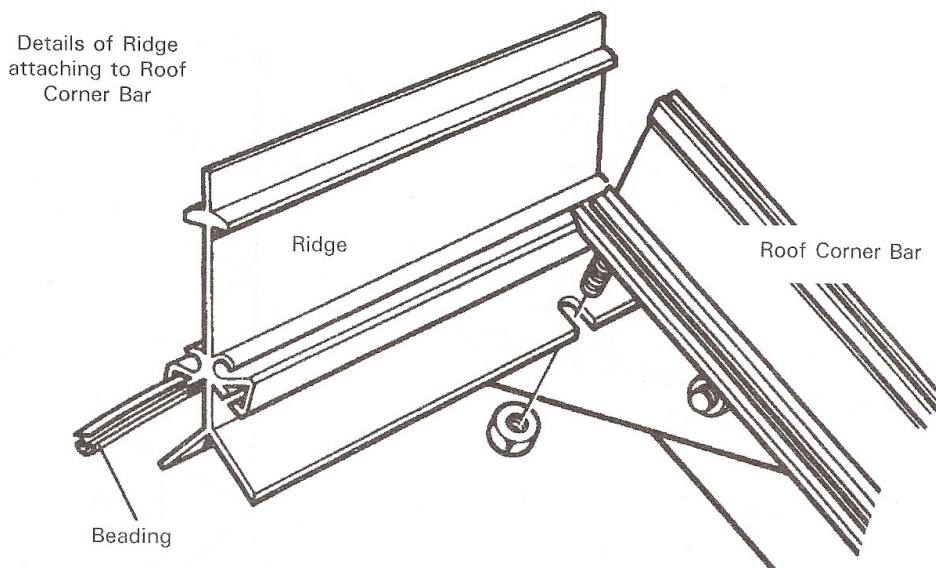

7. The roof bars can now be attached to the structure but first you must slide the glazing beading into the bars and trim to suit. **(Key point)**.

Attach the bars firstly at the ridge, sliding a bolt into the bolt slot of the roof bars and placing the bolt through the holes in the flanges of the ridge. Put a nut on and immediately prior to tightening ensure that the roof bar is pushed up hard against the ridge. Do not attach the bottom of the bars to the eave until all the roof bars are bolted to the ridge. **(Key point)**.

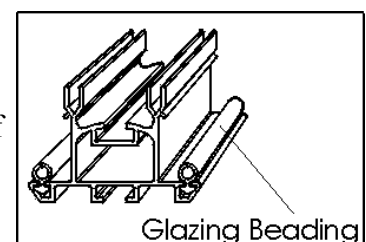

8. Slide 2 bolts into each roof glazing bar, 2 additional bolts into the 1st and last glazing bar on each side for the short horizontal angles and 1 additional bolt into each bar that a roof vent will cover. Do not put a nut on the bottom of the 2nd glazing bar from each end until the diagonal angle in point 11 has been fitted.

9. If you have ordered a partition, then leave 1 roof glazing bar out at the same position as you did during side frame assembly.

10. Now attach the bottom of the roof bars to the eave/gutter bar into the holes in the upper flange. Start with the middle bars either side of the ridge. Before tightening the nuts that hold the roof bar to the eave you must ensure that the roof bar is tight up against the small flange immediately above the gutter. **(Key point)**. Failure to observe this point and the previous one of keeping the roof bar tight up to the ridge could result in a slight outward bow of the gutters and a slight downward dip of the ridge.

11. At this point you will need to lift the structure onto a firm footing or the greenhouse base if you haven't already done so.

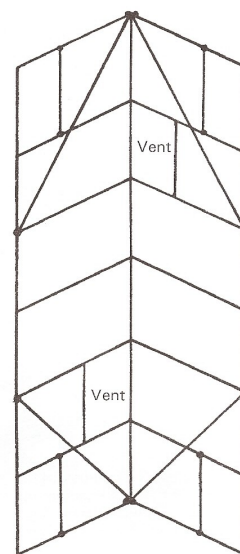
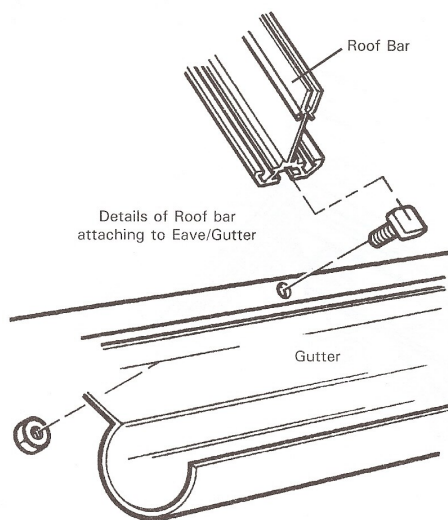
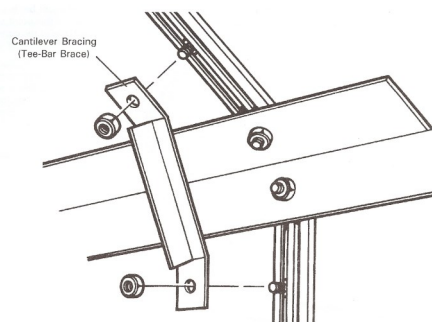

Plan of Roof Bars & Bracing Angle

12. On all models there are 4 roof diagonal angles and 4 short horizontal angles. The longer ones attach to the point where the ridge meets the roof corner bars and travels diagonally down to the gutter/eave bar at the point where the 2nd glazing bar is bolted. You fit one of these at each corner i.e. 4 per house. The short horizontal brace can now be attached to the middle of the roof corner bar to the last of the extra bolts inserted into the alternative bolt slots. The brace travels horizontally along to the first roof glazing bar and just below the point where the diagonal brace bolts to the bar, you can attach this short one.

13. You can now attach the T-bar cantilevers which bolt to each side bars and roof bars as illustrated, utilising the extra bolts inserted along the side frame assembly and roof assembly.

Before tightening these cantilevers up, make sure there is no sag in the ridge or outward bow in the eave. (Key point). If you have this problem you must straighten it out before tightening the cantilevers up. A bow or sag can easily be removed with 2 people pushing the gutters towards each other until straight, hold it in position whilst a third person tightens up the cantilevers.

The main structure is now complete and it must now be lifted onto its brick base for securing down.

10 BLADE LOUVRE

The louvre can not be fitted to any of the corner bays of the greenhouse.

Procedure

1. Place top cill into position on side jamb of louvre and secure with self tapping screws.
2. Do same on the other top corner.
3. Do same with bottom cill.
4. Please note that the handle is on the right hand side.

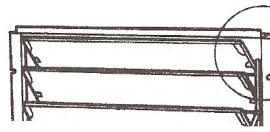

LOUVRE MODEL CONTAINS

- 1 Top cill
- 1 Bottom cill
- 2 Side jambs (one with handle)
- 4 Self Tapping Screws
- 4 1/2 Headed Bolts & Nuts
- Glass Blades

To fit the louvre to the greenhouse frame;

The louvre can be fitted to either of the centre bays at the rear, or the non corner bays of the side. The louvre **MUST** be sandwiched between 2 pieces of glass. It cannot sit directly on top of the bottom cill.

The louvre is fitted from inside the greenhouse, and you must ensure that the handles are on the right (viewed from inside).

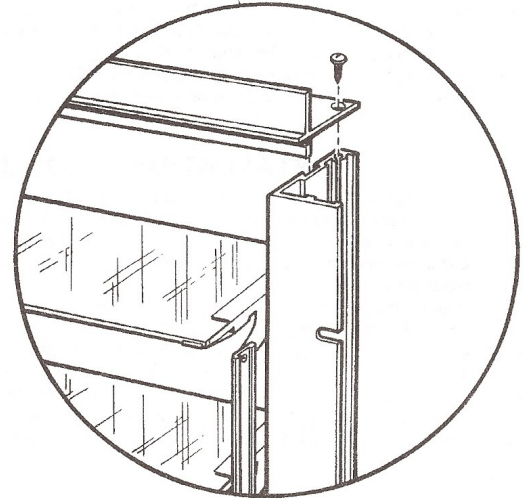

1. Decide which bay you intend to fit to, and fit 1 piece of glass on the bottom cill (either ref T6 or T5 depending upon the required louvre height).
2. Offer the louvre to the bay you intend to fit to and sit on top of the previously installed pane of glass.
3. Using the previously inserted bolts (or using 1/2 head bolts supplied) loosely fit the 4 brackets as shown to the greenhouse frame, and then tighten so as to clamp the louvre frame to the greenhouse.

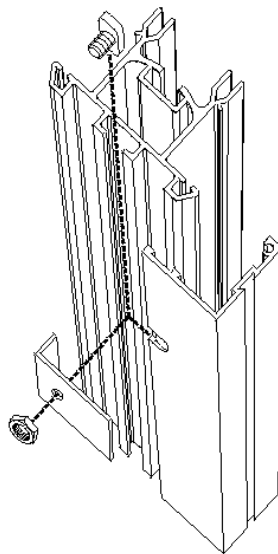

BRACKET FIXING TO
LOUVRE FRAME

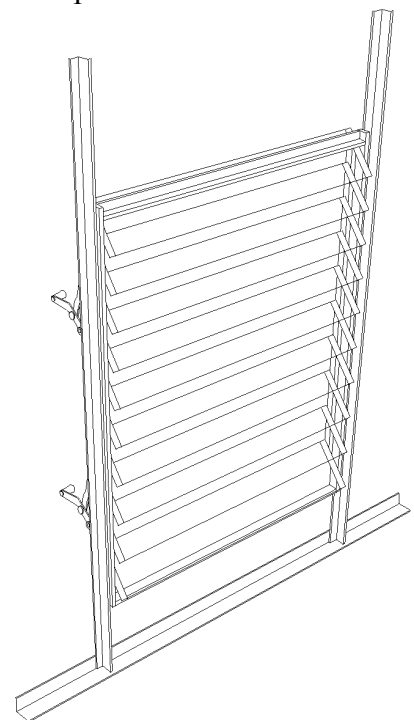

SECURING GREENHOUSE TO BASE

BRICK BASE

Having built your base level and square and to the outside measurements given earlier in the booklet, sit the greenhouse onto the brick base. The 4 cills will lip over the edge of the base and will protrude approx. $\frac{1}{4}$ " (7mm) all the way round. There are a number of small alloy angle brackets in the pack of fittings, these are bolted onto the upright glazing bars at the point where the cills are attached to them. You will have done this during subassembly.

Before bolting them to the frame, first mark the brickwork where the holes are to be drilled. Drill the holes with a masonry bit and insert a plastic plug. Secure the small angle to the uprights and screw through the hole in the angle into the plug as illustrated.

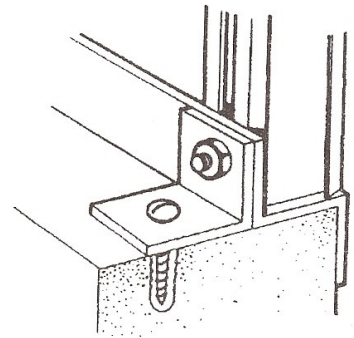

PARTITION

If you have purchased a partition it is at this point you construct the frame in situ. In the box you will find packs marked;

Partition corner bars

Partition door end cill

Partition door end

Partition door tracks

Partition door panels

Partition door posts (handed/unhanded)

You will also require a number of fittings from the box:

2 eave gusset plates, 1 ridge gusset plate

Glazing beading

Nuts and bolts

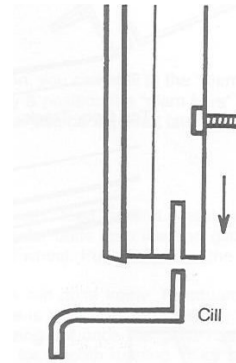

PROCEDURE

1. Starting with the corner bars, identify the roof and side, left and right hands as you did earlier.
2. Each corner bar has a saw cut approx. 20mm into the bar from each end, but apart from that they are identical. Insert the glazing beading as before – but this time into all 3 grooves of the corner bar. **(Key point).**

3. Having established where the partition is going you will need to make the holes in the gutter, ridge and cill into slots. Do this by carefully hacking sawing down into the hole to form the slot. **(Key point).**

4. Take the left hand side bar, insert 2 bolts into each of the 2 bolt slots, and then offer it up to the eave/gutter and cill so that the flange of the cill and the eave are inserted into the saw cut as shown above. **(Key point).**

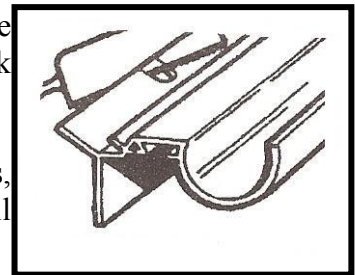

5. Slide the 2 bolts into the bolt slot facing inwards i.e. the alternative bolt slot of the corner bars to the holes in the cill and eave/gutter. Put a nut on and finger tip tighten. Do the same with the left hand roof corner bar, having first inserted 3 bolts into each bolt slot. (Don't forget to ensure that the "R" is at the ridge and **not** at the eave) now do the same with the other side and roof corner bars.

6. Next, offer the gusset plates to the corner bar at the point where they meet. Slide the bolts in the facing bolt slot towards the gusset plates and line up the holes in the gusset plate with the bolts in the facing bolt slot and in the flange of the corner bar. Insert 2 bolts through the gusset plate and flange (middle 2 holes), put a nut on – finger tip tight. Do not put the nuts on the upper and third bolts of the **eave** gusset plates at this stage. **(Key point).**

7. The cill can now be attached to the facing bolt slot of the partition corner bar (in the same way you did during the original door end assembly). N.B. If you have a brick base you will need to trim off with a hacksaw the first 2" of the overlapping part of the cill to facilitate a snug fit.

8. You can now attach the four vertical glazing bars. Thread the glazing beading into the channels and trim to suit. Put 3 bolts into the long block bar channel (closest to corner bar), 2 bolts into the channel closest to the door opening and 4 bolts into short glazing bars. 4 bolts into each slot, attach to the bottom cill by inserting another bolt into the slot and pushing it through the hole in the bottom cill. Moving to the top of the bar insert the top bolt through the hole in the roof corner bar. Put a nut on finger tip tight. Do the same with the other 3 glazing bars.

9. Utilising the bolts inserted into each bar, attach the horizontal and diagonal bracing bars in the same way as the original door end. Likewise with the door track support, attach as before. The door in a partition is assembled and hung in the same way as the front gable doors, but is usually lower than the front door.

For both double and partition-door ends you can now fit the upper door track.

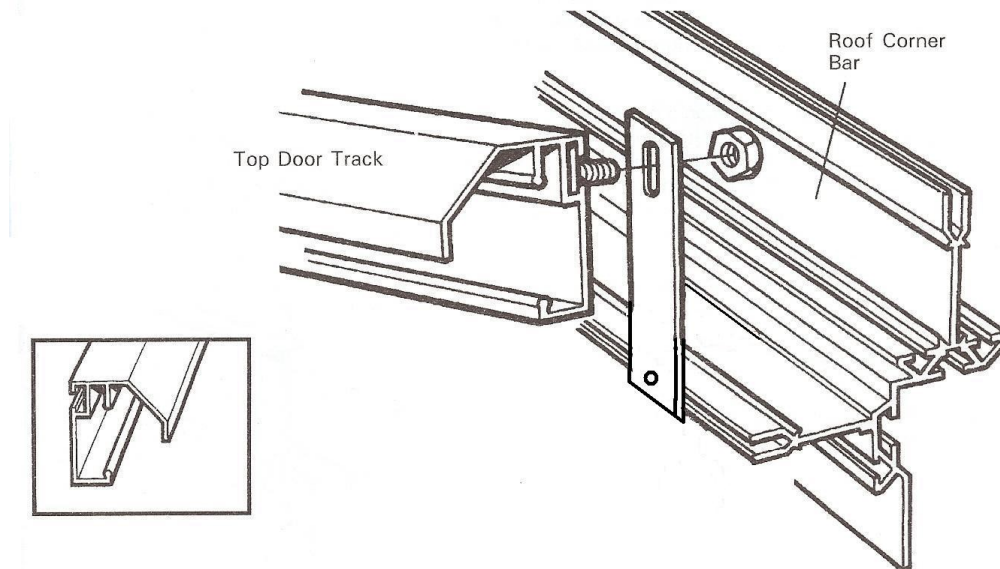

EXTERIOR DOOR TRACK

This top door track has no holes in, but 1 bolt slot. Insert 3 bolts into the bolt slot and line them up with the 3 holes in the door track support, put the nuts on and tighten up. To move the door track into the correct position, fit the doors (see below for door fitting) onto the track and by slightly releasing the nuts holding the door track support you can move the doors up and down until they are correctly into the bottom guide. In the bag of fittings, you will find 2 small flat bars which each have 2 holes of different size. Attach the larger of the 2 holes in the flat bar, to each end of the top door track using the bolt channel at the back. Before tightening, slide the flat bar along the door track until the smaller hole in the flat bar intersects the self tapping screw groove in the roof corner bar. Tighten, and repeat the procedure at the other end of the track.

PARTITION DOOR TRACK

This door track is fitted in exactly the same way as the exterior door track so the instructions above apply.

N.B. The small flat bar illustrated is fitted pointing **downwards** for the partition. (**Key point**).

FITTING THE DOOR TO THE STRUCTURE

The doors slide onto the frame from the left and right hand sides.

Put the door bottom panel into the bottom door track and slide to the left/right, feed the first wheel into the upper door track and move further to the right/left and feed in the second wheel. Push further to the right/left until the draught excluder (in the outer door post) is butting up to the end glazing bar. The doors will now run quite freely. To square up the doors with the spacing, undo the upper bolts holding the door track support. There is a little play to facilitate “fine tuning” of the door.

FITTING THE DOUBLE DOOR LOCK

The door lock must be fitted after the doors are in position. **(Key point).** Undo the ring bolt from the door lock, and insert the barrel through the hole in the panel from the outside. Reattach the ring bolt to the barrel on the inside, and tighten.

Now attach the cam lever, washer and screw to the door lock from the inside position of the door. The lock will turn through 90 degrees both ways, so you must ensure the cam (when fitted) is pointing skywards (unlock position) and horizontal (locked position).

Now using a cropped head bolt, attach the domed pin to the bolt channel of the handed door post on the left hand door (viewed from outside). Move the pin up or down in the channel so that the notch on the cam locates comfortably when horizontal. Tighten all components.

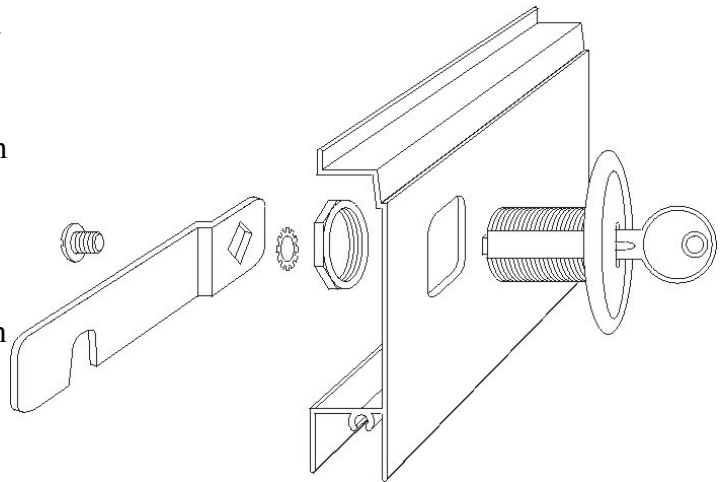

The small glazing bar above the middle of the door can now be fitted. Put the glazing beading into the grooves and trim to suit. Insert 2 bolts into the bar and put them through the holes in the top door track and apex gusset plate. Put nuts on and tighten up.

FINISHING OFF

To prevent the door from sliding past its opening, you must fix 2 angle brackets to the door end assembly. Insert a cropped head bolt into the bolt channel at the top of the left hand glazing bar (viewed from the inside) and fix an angle bracket as shown in the picture below.

The bracket must be fitted at the same height as the door panel so that, as the door moves left or right, the bracket prevents the door from moving too far along the top door track.

Repeat at the bottom of the door.

Repeat for the 2nd door.



To facilitate smooth running of the door, fit 1 flat bar/door track support at each end of the top door track. The angle has 2 slots at one end of the bar, and nothing at the other. Attach one of the slots to the bolt channel of the back of the door track using a bolt. The blank end of the angle will hang down and line up with the self tapping screw groove on the 'front facing' part of the short glazing bar. Drill a small hole (3mm) in the angle to secure to the corner bar using a screw. Repeat at the other side of the door track.

FITTING THE VENT

Before sliding the vent on to the ridge, slide a piece of black tube into the vent hinge socket as illustrated. Slide the vent into position, insert a small self-tapping screw into the black tube half way along, and then tighten the screw. The tube will expand and lock into position, preventing sideways movement of the vent. Having slid the vents from the end of the ridge to the desired position, you can now fit the “slam bars” to the roof glazing bars. Utilise the bolts you inserted during general assembly and position the “slam bars” just underneath the vent allowing the casement stay to effectively close. The slam bar can be adjusted later to facilitate good opening and closing of the vent, and correct glass position for underneath the vent.

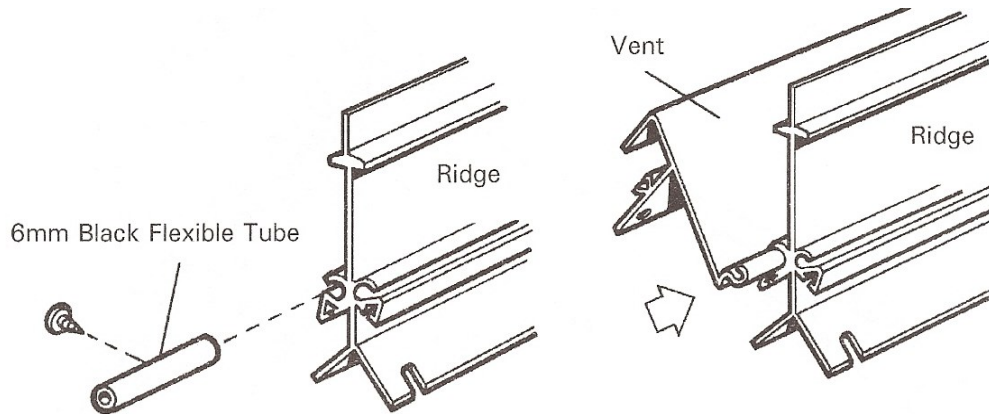

FITTING THE ROOF CANOPY

This must be done AFTER the roof vent(s) is/are fitted.

The canopy is fitted on top of the ridge bar, and is slightly longer than the ridge. If your greenhouse is over 8' long, then the canopy will be made up using several pieces.

First sit the canopy on top of the ridge and position the canopies so that the overhang at each end of the ridge is the same and that the end of the canopy is level with the outer edge of the roof corner bars.

Drill through the ridge (7mm diameter hole) and canopy at each end. Insert a bolt, and secure on the other side with a nut.

Now insert the canopy seal to each side of the canopy into the seal channel, and feed along so that it is level with the ridge at each end.

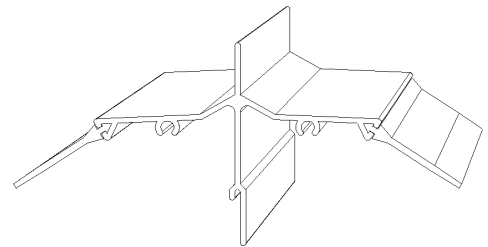

FITTING THE CANOPY PLATE

The canopy plate has 3 holes. Slide a LONG bolt (provided) into the external bolt slot of the glazing bar above the door and the central glazing bar at the rear. Fit the canopy plate to this bolt, and put a nut on. Do not tighten yet. Now the top 2 holes in the plate are fitted to the self tapping screw grooves in the ends of the roof canopy using 1/2" colour coded screws provided. Tighten all screws and nuts.

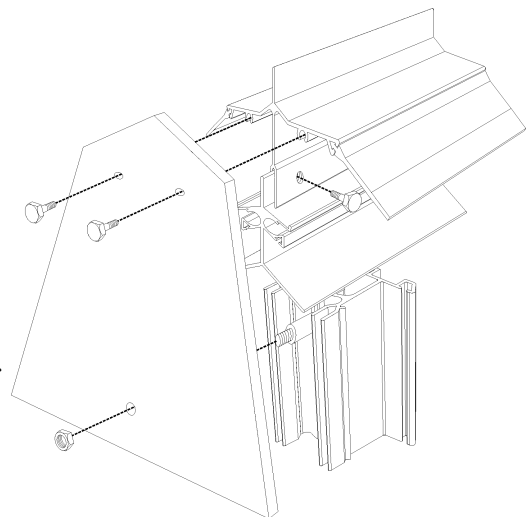

TOUGHENED GLASS

Always handle glass with extreme care as failure to do so can result in injury. Your greenhouse is supplied with PVC bar capping and you will find the bar capping installation instructions with the bundle of capping. Your greenhouse is glazed using both wire clips and then bar capping on top.

Wire Clips

Start with the panes of glass on the side (see glazing plan later in this booklet), Insert 4 wire clips as illustrated, put one 'wing' of the clip under the ridge at the front of the bar, then insert the two shoulders just behind the edge of the glass. The other 'wing' of the clip, which is not yet engaged in the bar can now be pushed downwards until it clicks into and under the ridge on the front of the glazing bar. 2 on either side of the pane approx. 100mm from the bottom and the top. The upper 2 clips approx. 1/2" (13mm) from the top edge of the glass. Now insert the intermediate clips so as to have 8 clips per large pane.

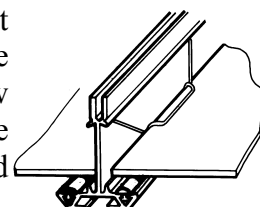

Bar Capping should be fitted 'as you go along'. You need access to the top of each roof cap to screw into position, so you will need to poke your head up in the next bay along to enable safe fixing.

With single sheet toughened glass the traditional overlap system used with the horticultural glass is replaced by a rigid P.V.C muntin. Muntins are only used where 2 pieces of glass butt together. Position the muntin on top of the lower pane of glass taking care to have the inside and outside as indicated. Put the next pane on top of the muntin (into the rebate) and clip the glass in, as previously described. There are enough stainless steel clips in your kit for 8 clips per large pane of toughened glass over 1.2m.

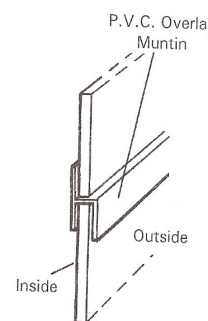

REF/ SIZE	T3	T5	T15	T16	T17	T51	T52	T53	T54	T58	T63	T64	T65	T66	T67	T68	T69	T70	T71	T72
10x10	2	1	4	2	10	4	5	1	4	4	4	4	2	2	2	2	2	2	2	2
12x10	2	1	4	2	10	4	7	1	4	4	4	6	2	2	2	2	2	2	2	2
14x10	4	1	4	2	10	4	9	1	4	4	4	6	4	2	2	2	2	2	2	2
16x10	4	1	4	2	10	4	11	1	4	4	4	8	4	2	2	2	2	2	2	2
18x10	6	2	4	2	10	4	12	2	4	4	4	8	6	2	2	2	2	2	2	2
20x10	6	2	4	2	10	4	14	2	4	4	4	10	6	2	2	2	2	2	2	2

Louvre must be fitted on the side. Replace T52, louvre can not replace T51.

POLYCARBONATE GLAZING

For Polycarbonate glazing, there are no muntin/glass joining strips. The rectangle and shape pieces are 1 piece together.

The Polycarbonate is UV treated on one side, so check the label on each piece to ensure it is fitted correctly. UV side goes to the outside of the greenhouse.

Your greenhouse is now complete!

TOUGHENED GLASS

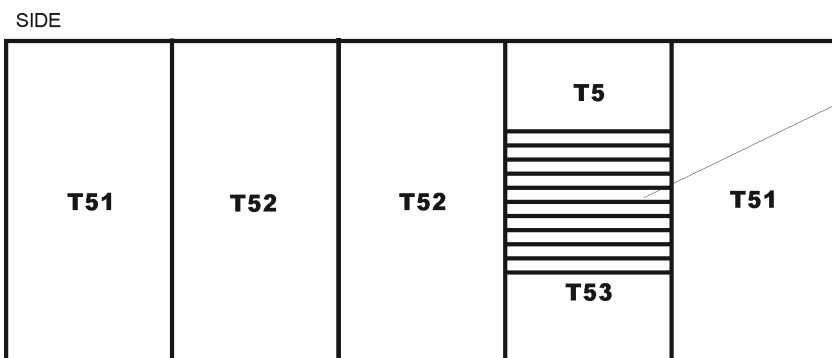
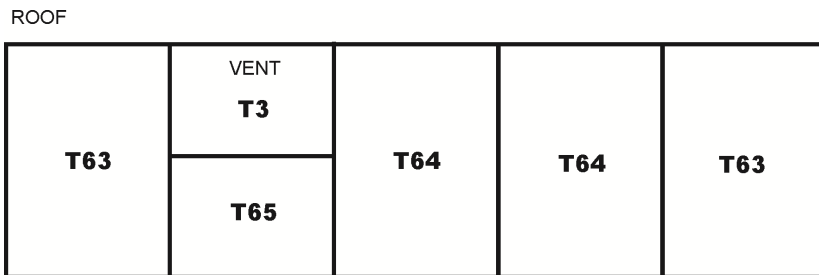
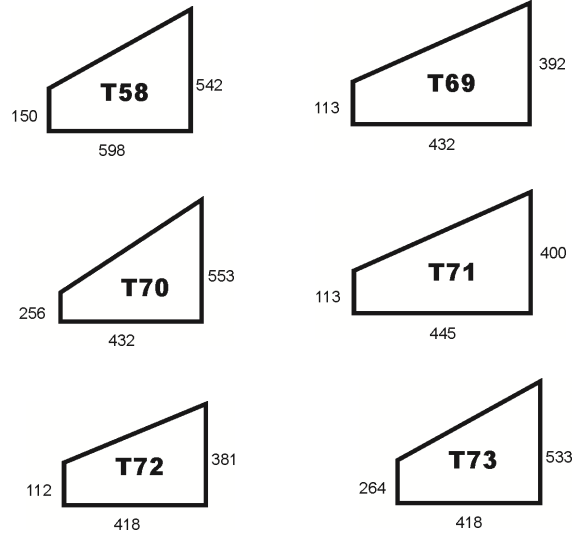
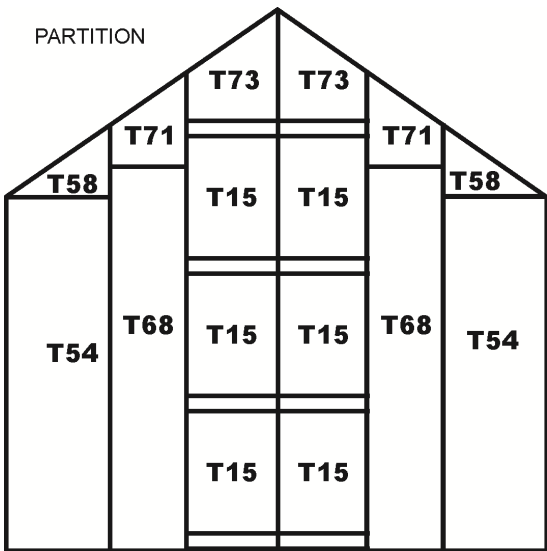
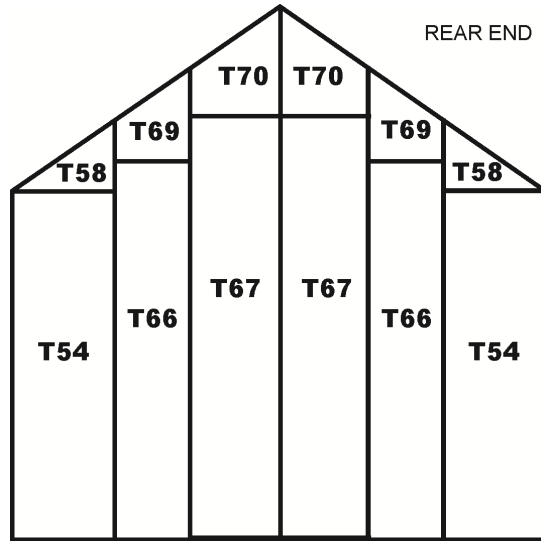
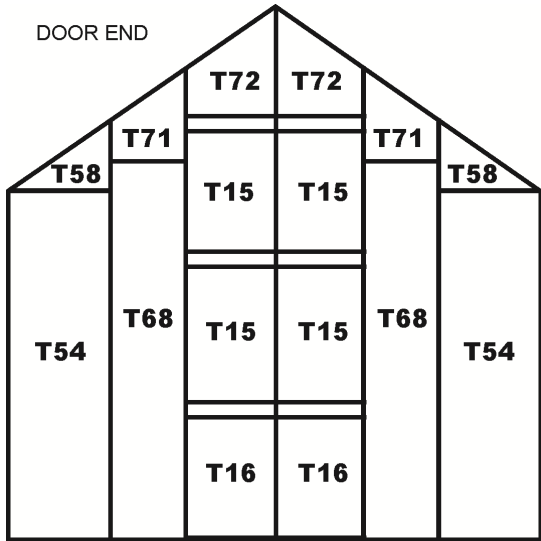

CODE	WIDTH (mm)	LENGTH (mm)
T3	640	904
T5	585	177
T15	450	457
T16	450	610
T17	545	100
T51	598	1345
T52	585	1345
T53	585	243
T54	598	1185
T63	598	1865
T64	585	1865
T65	585	976
T66	432	1630
T67	432	1780
T68	445	1630

ELITE 1608