

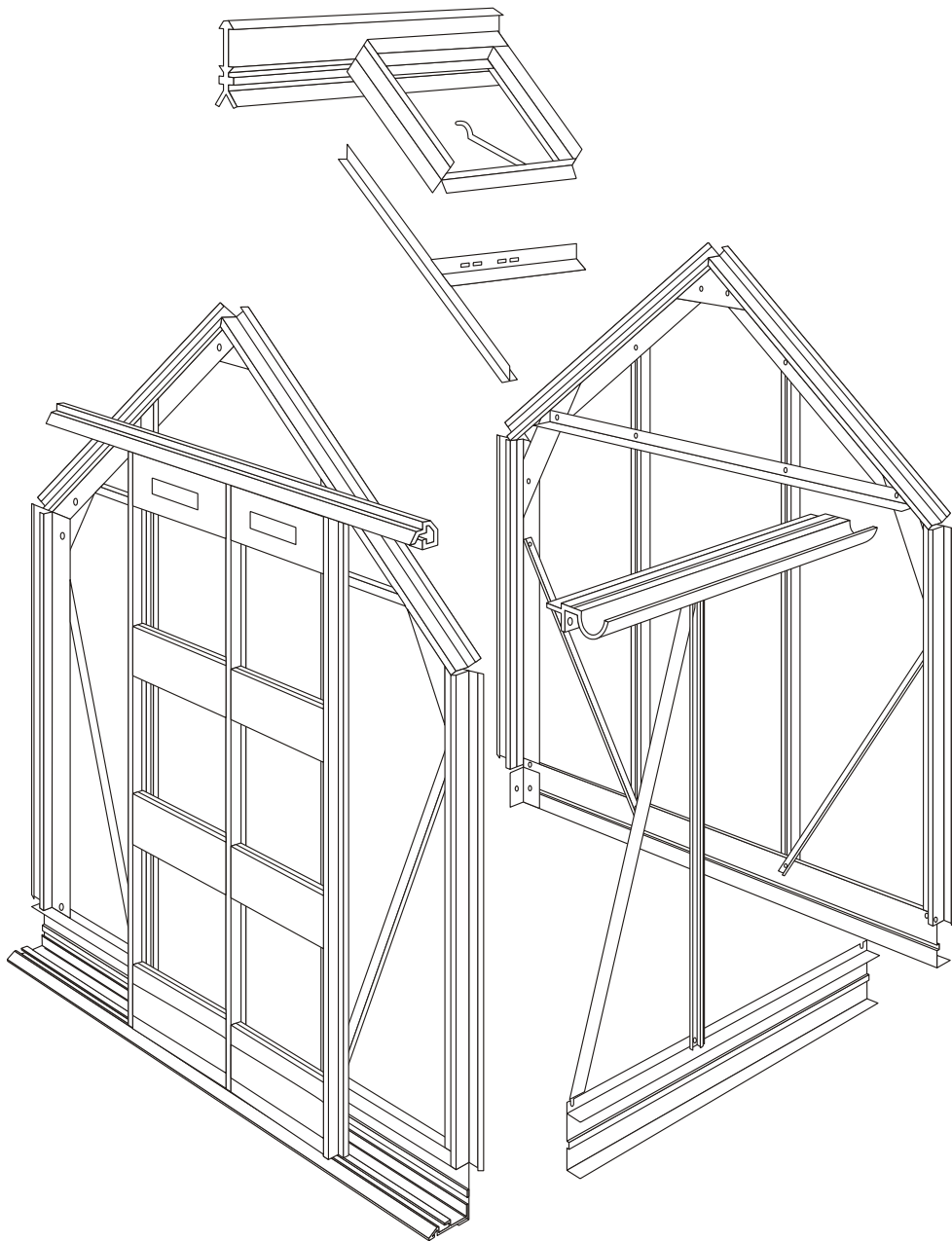

INSTRUCTIONS & ILLUSTRATIONS FOR THE
4'3" WIDE COMPACT



ELITE GREENHOUSES LTD

BENT SPUR ROAD, KEARSLEY, BOLTON BL4 8PD

TEL: 01204 791488 FAX: 01204 862412

enquiries@elite-greenhouses.co.uk

www.elite-greenhouses.co.uk

FITTINGS WITHIN THE KIT (NOT TO SCALE)

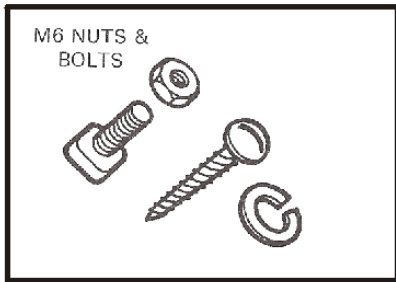

M6 NUTS & BOLTS
SELF TAPPING SCREWS
SPRING WASHER

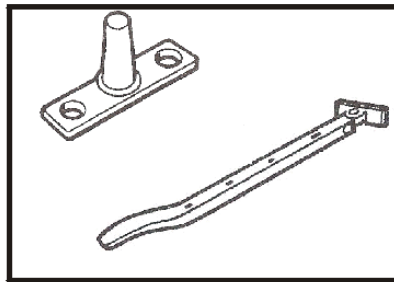

CASEMENT STAY + PINS

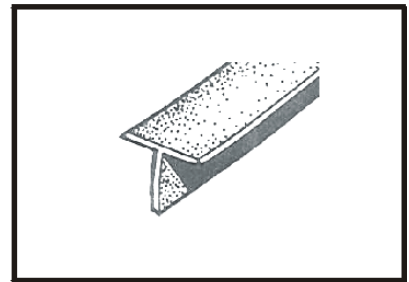

DRAUGHT EXCLUDER

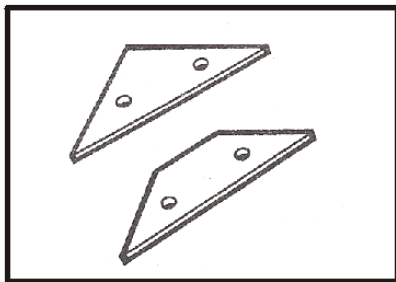

APEX & EAVE GUSSET PLATES

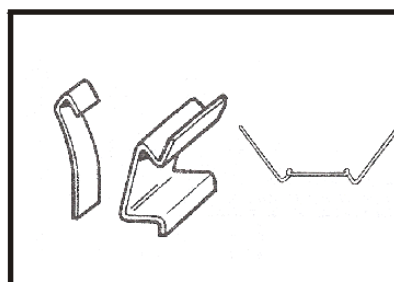

OVERLAP, SPRING + WIRE CLIPS

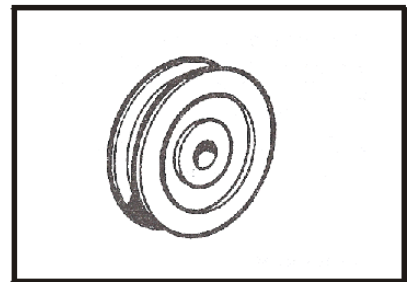

DOOR WHEEL

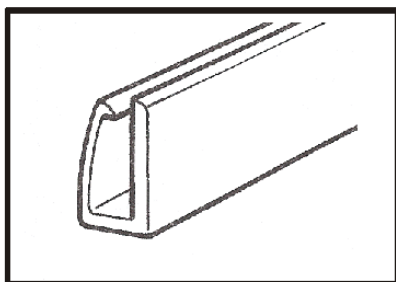

BLACK DOOR SKID

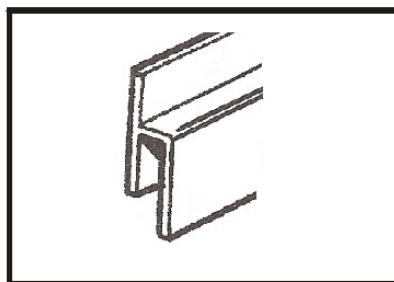

MUNTIN

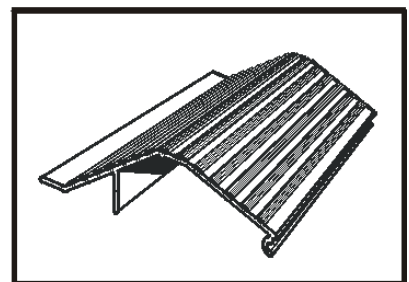

RAMP

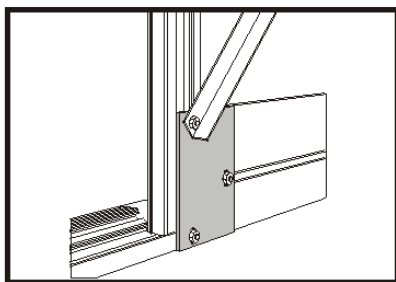

DOOR END PLATE

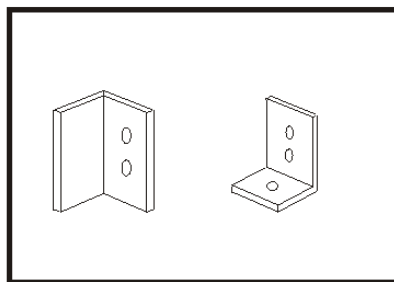

DOOR STOP & ANGLE BRACKET

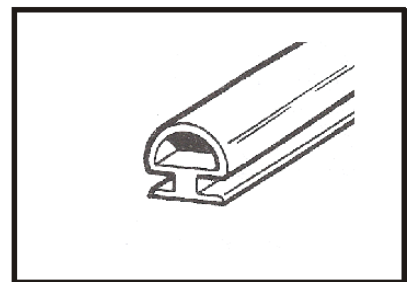

NEOPRENE BEADING

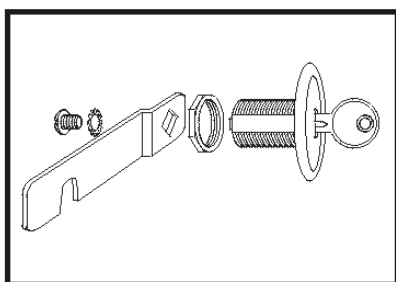

DOUBLE DOOR LOCK

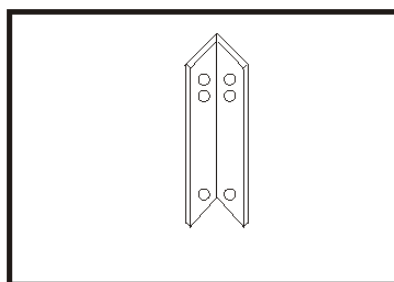

CORNER BRACKETS/BASE LEGS

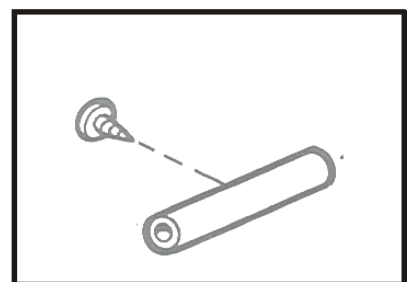

VENT STOPPER

COMPONENT DRAWINGS (NOT TO SCALE)

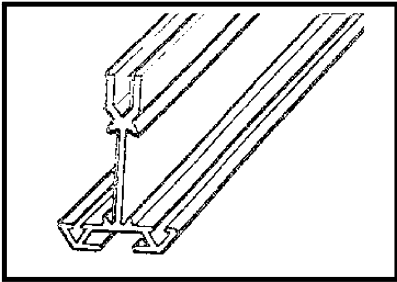

GLAZING BARS AND DOOR POSTS

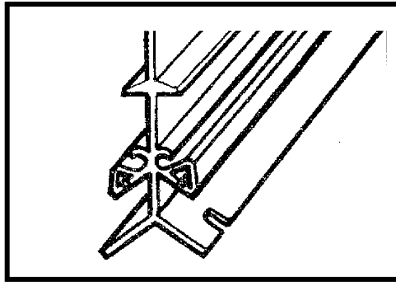

RIDGE

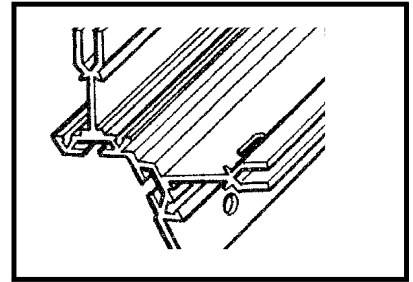

CORNER BAR

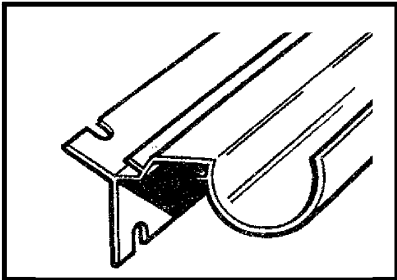

COMBINED EAVES BAR/GUTTER

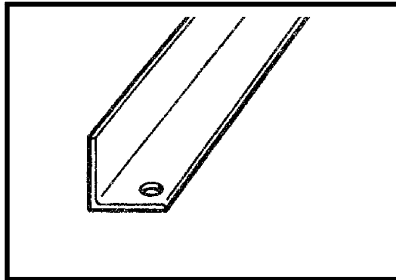

BRACING ANGLE

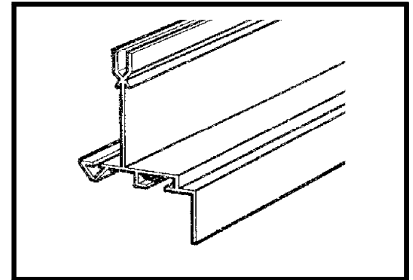

VENT SIDE RAIL

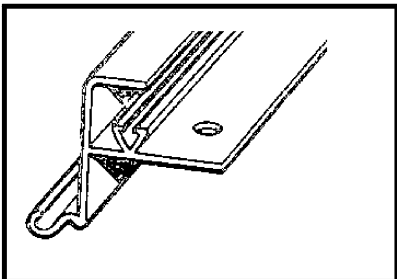

VENT TOP RAIL

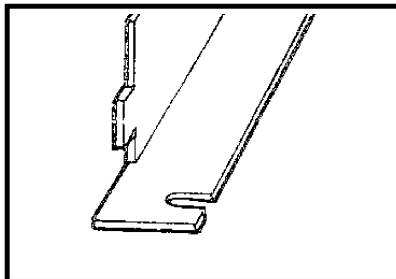

VENT SLAM BAR

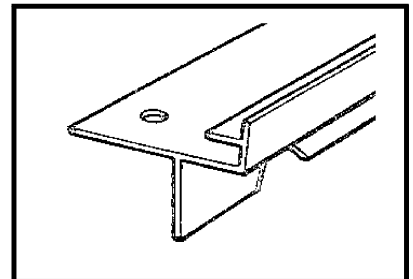

VENT BOTTOM RAIL

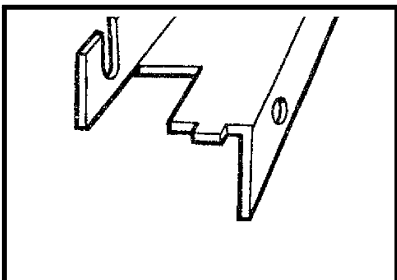

DOOR TRACK SUPPORT

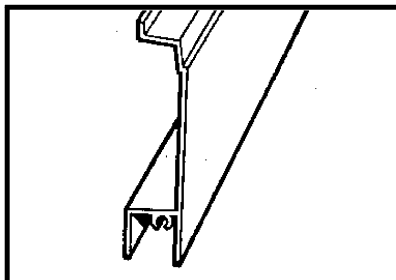

MIDDLE DOOR PANEL

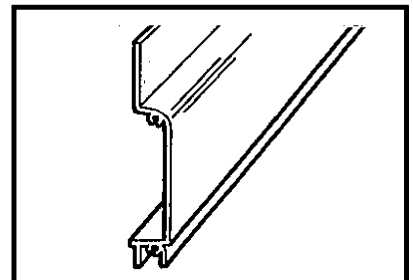

DOOR TOP/BOTTOM PANEL

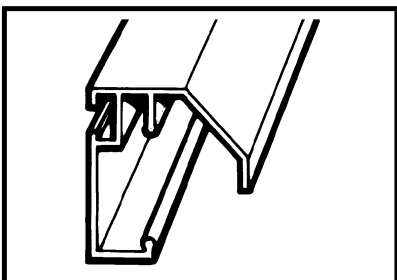

TOP DOOR TRACK

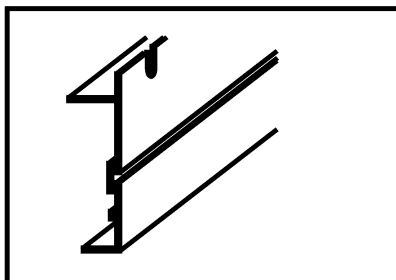

BUILT IN BASE

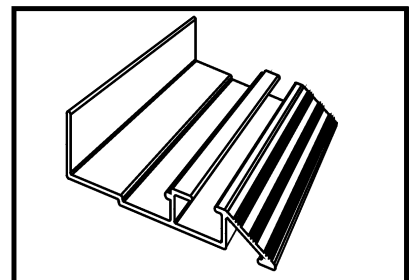

DOOR END CILL

PARTS LIST

			4 X 4	6 X 4	8 X 4	10 X 4
1	Nuts and bolts M6		90	100	110	124
2	Wire clips		174	214	254	298
3	Overlap clips		26	32	38	44
4	Casement stay		1	1	1	2
5	Stay pins		2	2	2	4
6	Pins, nuts and bolts M4		6	6	6	12
7	Double door lock		1	1	1	1
8	Self tapping screw		28	28	28	28
9	Glazing beading—meters		49	58	68	77
10	Door skids		2	2	2	2
11	Eaves plates	Taped together with one casement stay	4	4	4	4
12	Ridge plates		2	2	2	2
13	Door wheels and fittings		4	4	4	4
14	Ridge		1	1	1	1
15	Combined gutter/eave		2	2	2	2
16	Built in base side		2	2	2	2
17	Side bracing angle		2	2	2	4
18	Door end built in base		2	2	2	2
19	Top door track		1	1	1	1
20	Top door panel	With name plate taped together and marked door	2	2	2	2
21	Bottom door panel		2	2	2	2
22	Middle door panel		6	6	6	6
23	Door track support		1	1	1	1
24	Door posts (2 unhande d 2 handed)		4	4	4	4
25	Side glazing bar		2	4	6	8
26	Roof glazing bar		2	4	6	8
27	Vent (in packs)		1	1	1	2
28	Door end glazing bars	Taped together and marked door end	2	2	2	2
29	Door end horizontal angle		2	2	2	2
30	Door end bracing angle		2	2	2	2
31	Door track support flat bar		2	2	2	2
32	Rear end built in base		1	1	1	1
33	Rear end glazing bars	Taped together and marked rear end	2	2	2	2
34	Rear end horizontal angle		1	1	1	1
35	Rear end bracing angle		2	2	2	2
36	Corner bars in two packs		8	8	8	8
37	Glass (see glazing plan in back of booklet)					
37	Door draught excludes		2	2	2	2
38	Corner brackets		4	4	4	4
40	Angle brackets		6	8	10	12

HELPFUL HINTS

Please do take your time and be sure to read all instructions carefully before assembling.

Consider purchasing the Elite Installation tool kit – see accessory brochure for contents of kit.

Do not assemble frame in high winds.

The greenhouse frame should be anchored to a permanent foundation. This will not only help secure it against powerful winds but will help prevent breakage of the glass caused by the freezing and thawing process of the earth.

When building your own brick/concrete foundations ensure that they are level and square otherwise your frame will not be correct and the glass will not fit.

Be sure all four corners of the constructed greenhouse are square before installing glass, and do not install the glass till the greenhouse is on a permanent foundation.

Do not place your greenhouse in vulnerable locations such as under trees, playing areas, etc.

Children should not play near glass greenhouses.

REMEMBER: glass is fragile, handle with care!

Protective eye glasses should be worn.

Gloves should be worn.

If your greenhouse is a painted one there are a few 1/8" (3mm) holes in the end of the bars. These are jig holes for painting and have no bearing on construction. **(Key Point)**.

WHEN CONSTRUCTING A POWDER COATED MODEL PLEASE TAKE CARE NOT TO DAMAGE THE FINISH BY WORKING ON CONCRETE OR PATIOS. Take great care in opening the polythene packages. Do not run a knife down the side of the packs as this may scratch the paintwork.

N.B. This plan covers the entire Compact range. The only difference between a 4ft long and a 10ft long for example are a few extra pieces of alloy, glass, nuts and bolts etc. The construction of the sub-frame assemblies are the same but for the purposes of this booklet we have used the 4 x 4 model as the benchmark. Therefore only one plan is needed.

We reserve the right to alter and improve our products.

INSTALLATION INSTRUCTIONS FOR THE 4'3" WIDE MODEL "COMPACT RANGE"

The contents of this carton are divided into the different frame assemblies that collectively make up the completed greenhouse framework.

It is recommended that each framework assembly is fully completed before moving onto the next.

The contents are as follows:

1. Two side frames
2. Rear end frame
3. Door end frame
4. Roof vent
5. Doors
6. Bag of fittings containing:
 - Nuts and bolts general assembly
 - Overlap clips for glass
 - Spring clips for glass
 - Casement stay
 - Casement stay nuts and bolts
 - Four eave plates (not in the main bag, but taped up with the casement stay)
 - Two ridge plates
 - Four door wheels
 - Two door guides
 - Small self tapping screws
 - Double door lock
 - Rectangular plates (3 elongated holes)
7. Roof bars
8. Coil of glazing beading
9. One length of ridge
10. Two draught excluders

For clear identification of parts and the number required please carefully refer to the earlier pages of component drawings and parts list.

SIDE FRAME ASSEMBLY

Components

1 Combined gutter/eave bar

1 Built in base

Glazing bars—1 if 4' long

2 if 6' long

3 if 8' long

4 if 10' long

5 if 12' long

Bracing angle 1 if 4' or 6' long

2 if 8', 10' or 12' long

From the fitting list you will require nuts and bolts and glazing beading.

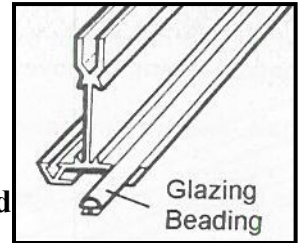

STARTING with the side frame.

With a built in base model the base is an integral part of each frame and is therefor not built as a separate entity.

Slide the glazing beading into each side bar taking care not to stretch the material. Trim off any surplus, level with the ends of the glazing bar.

Lay out the pieces on the ground as though you were standing inside the house i.e. with the gutter and built in base facing downwards and the bolt channel of the glazing bars upwards. **(Key Point)**

Slide a bolt into each end of each glazing bar into the bolt slot on the back of the bar. If you have bought a shelf to go in your greenhouse and you intend to fit it on a side wall, use the ½" headed bolts provided with the shelf fittings.

Fix the combined eaves bar and gutter to the glazing bars pushing the bolts through the holes in the eaves bar and securing with a nut. You do not need to tighten the nuts too much at this stage, but they need to be tight enough to stop the bolts slipping out of the glazing bar.

Fix the built in base to the middle glazing bar by pushing the bolt through the hole in the built in base and tightening as before. (4' long model will only have 1 side glazing bar per side assembly, 2 for the 6' etc.).

Correctly position the built in base on the outermost glazing bars by pushing the bolts through the holes in the built in base, but do not put the nuts on yet. (6', 8' and 10' models only).

Place the side bracing angle over these bolts so that they point outwards towards the ends of the eaves bar. They must be arranged so that the flat bit of the angle in each case faces towards the middle of the house (i.e. elongated hole will be by the eaves in one case and by the built in base in the other. **(Key Point)**). 4' and 6' long model will have 1 side bracing angle per side. This is to attach to the top of the 1st glazing bar and then will attach to the gable end during general assembly, at the base.

Put nuts on the bottom bolts and lightly tighten.

Do the same with the other side frame assembly.

Make sure that the glazing bars touch both the built in bases and the combined eaves gutter bar in each case. Tighten all nuts.

If you are fitting your greenhouse onto hard standing (flags, concrete etc), then insert bolts into the bolt channel of the built in base (generally 1 every 2'). These will be used to anchor the greenhouse to the floor during general assembly. Do not insert these bolts if you intend to install your greenhouse on to soft ground.

BEWARE OF SHARP EDGES!

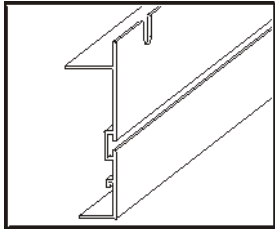

BUILT-IN BASE

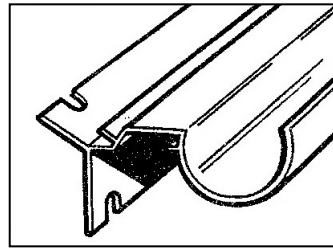

Combined Eaves Bar and Gutter

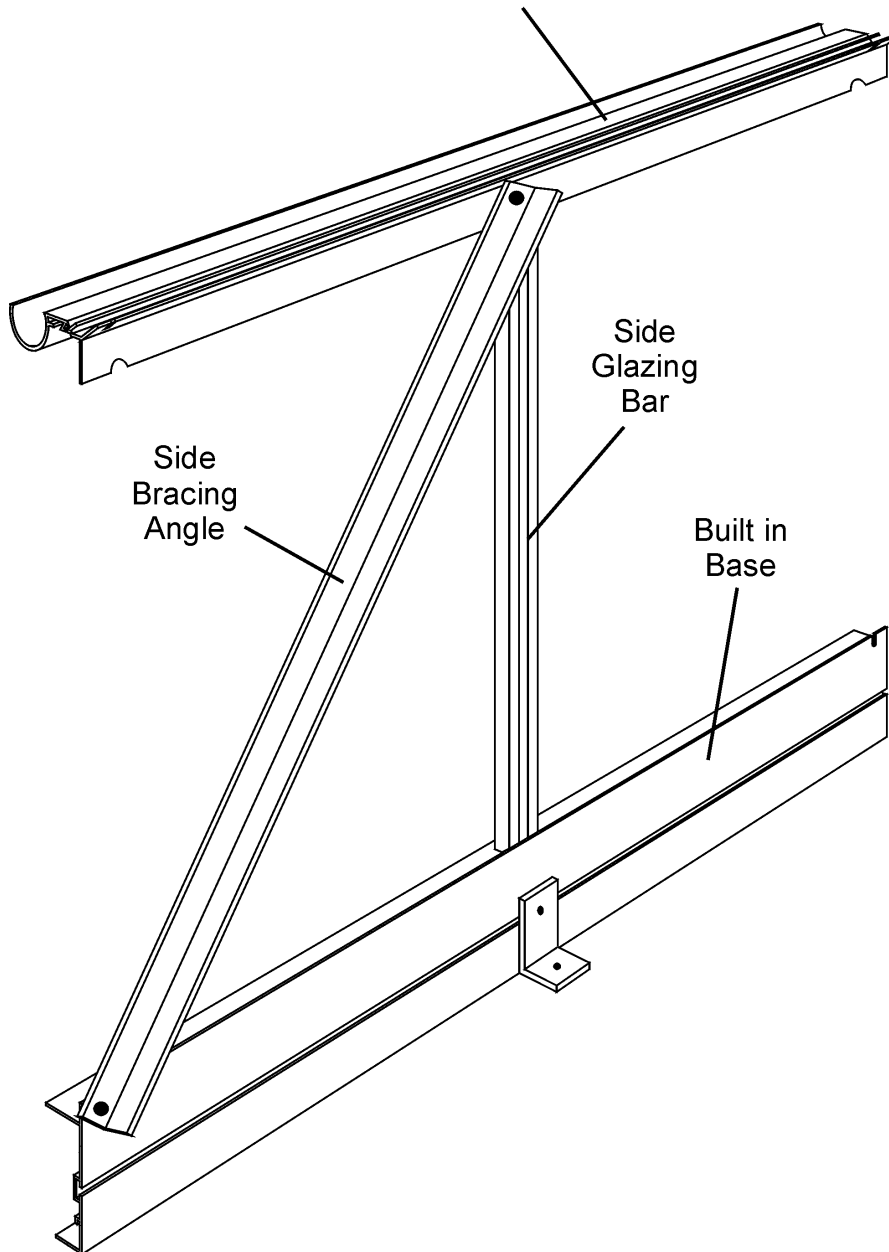

REAR END ASSEMBLY

N.B. The roof corner bars are marked “R” on the outside, which indicate that they meet at the ridge and are also mitred at both ends. If you have a painted greenhouse there is no letter “R” on the corner bar. You **must** ensure that the “middle” hole is nearer to the eaves plate than the ridge plate. **(Key Point).**

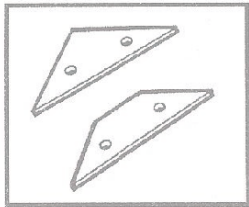

Apex and Eave Plates

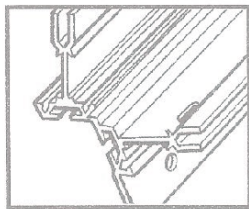

Corner Bar

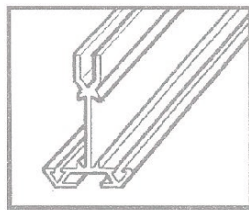

Glazing Bar

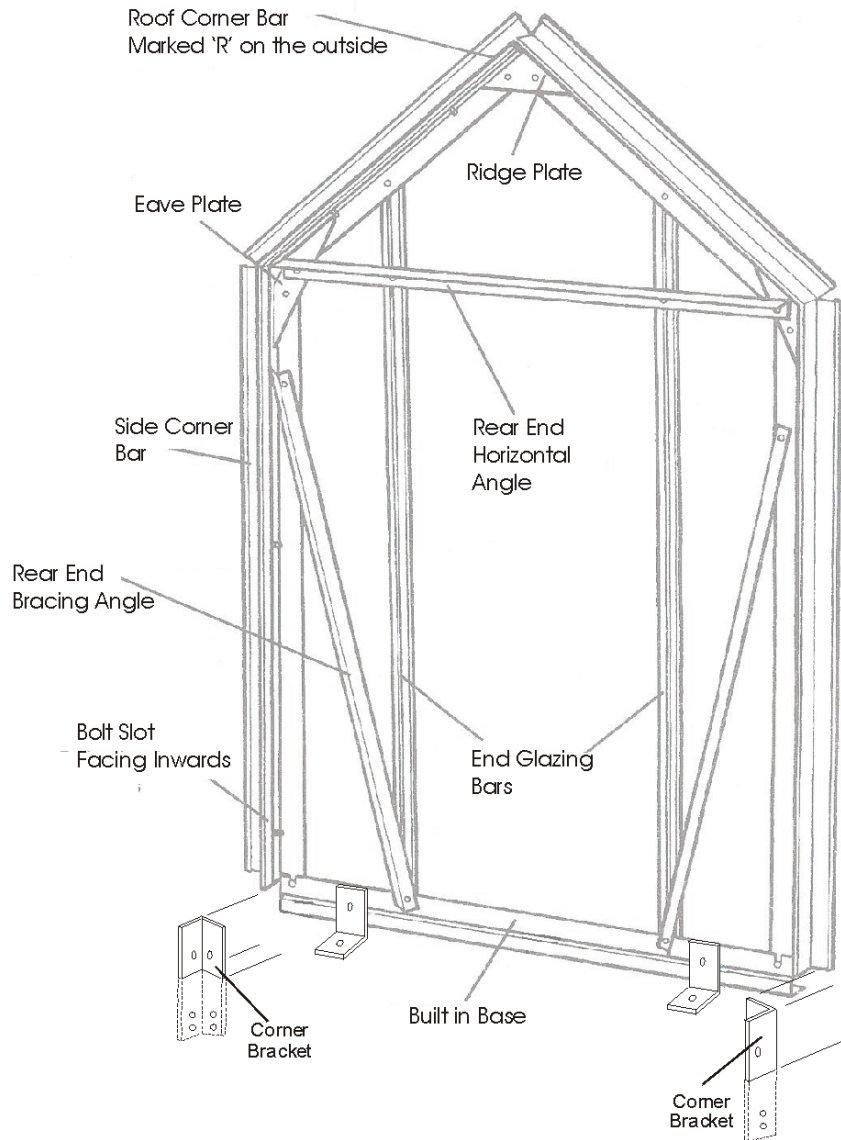

Detail of eave assembly viewed from inside

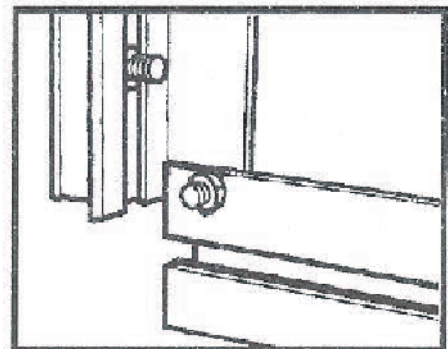
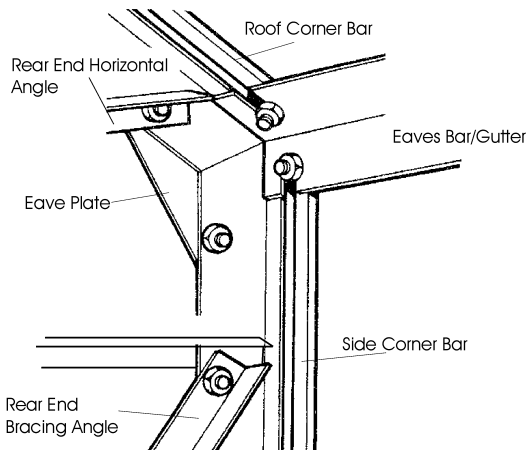

Built in Base/Corner Bar

From the main bag of fittings you will require the nuts and bolts, two eave plates and one ridge plate. These are packed with the casement stay and are separated from the main bag of fittings.

Components:

1 alloy built in base

2 glazing bars

2 rear end bracing angles

1 rear end horizontal angle

2 roof corner bars (marked "R" at the apex)

2 side corner bars (unmarked)

Corner bars are in two packs of 4 and are identical for both gables. They are marked "corner bars".

INSTRUCTIONS

1. Slide the glazing beading into each glazing bar and corner bar taking care not to stretch the material. Trim off any surplus level with the ends of the glazing bar. The corner bars have 3 grooves to receive beading. **Do not** use the middle one, only the two outer grooves require beading.

2. Lay out the frame as though you were standing on the inside i.e. with the bolt slot uppermost, roof corners marked "R" at the apex, opposite each other, facing downwards (i.e. "R" on outside). The roof corner bars are mitred at both ends where as side corner bars are mitred at one end only (**Key Point**). The bolt slot is on the inside and faces inwards during initial construction. If you have a painted greenhouse there is no letter "R" on the corner bar. You **must** ensure that the "middle" hole is nearer to the eave plate than the ridge plates. (**Key Point**).

3. Slide two bolts into the bolt channel of each corner bar, put a nut on and finger tip tighten approx. 3" from the end of the bar. These will later be used in the general assembly for fixing the ridge, eave and built in base to the ends. Now secure the ridge plate and eaves plates by inserting bolts through the 'plates' and into the holes punched in the flange of the corner bar, at the apex and eave. Do not tighten the nuts and bolts in the plates at this stage, finger tip tighten is sufficient.

N.B. If you have the 4' option the roof vent slam bar will attach to one of the corner bars. You will need to insert an extra bolt into the bolt slot of the roof corner bar onto which the vent will close.

4. Attach the built in base to the side corner bars by inserting a bolt through the hole in the flange of the corner bar and into the slot in the built in base.

5. Attach the vertical glazing bars to the built in base by inserting a bolt into the bolt channel of the glazing bars and locating it with the punched holes in the built in base. Before securing the nuts attach the rear end bracing angle which goes diagonally from the spare hole in the corner bar near to the eave plate down to the built in base to the same bolt as illustrated. The top of the diagonal angle tie now attaches to the pre-fabricated holes approx. 8" from the top of the side corner bar.

6. Slide two bolts into the bolt channel at the top of the two vertical glazing bars and secure the second one to the roof corner bars by inserting the bolt through the punched hole in the flange.

7. You can now attach the rear end horizontal angle to the **top bolt** of the eave plate and to the other bolts in the glazing bars you inserted in 6, above.

8. Check that all angles between built in base and the vertical members are at right angles and that the glazing bars are right into the built in base at the bottom. **(Key Point)**.
9. Tighten all nuts.
10. Slide two extra bolts into the built in base. This will be used later to attach the corner bracket.
11. Slide a bolt into the bolt slot in the built in base section, one at each end. Attach the corner bracket so that it is pointing downwards. If you are fitting your greenhouse onto soft ground, then do not fit the corner bracket yet. If you are on a patio, you will need to cut the bracket off, level with the bottom of the built in base and slide extra bolts into the bolt channel to be attached to the corner bracket (generally 1 every 2'). If you are on soil, the corner bracket will go into the ground at general assembly.

DOOR END ASSEMBLY

From the main bag of fittings you will require the nuts and bolts, 2 eave plates and 1 ridge plate. These are packed with the casement stay and are separate from the main bag of fittings. Please note, you only require approx. 40mm of beading in the inside 'v' groove of the end glazing bars.

Components

- 2 door end built in base
- 2 end glazing bars
- side corner bars (unmarked)
- top door track
- door end horizontal angle
- door end bracing angles
- main door track support
- 2 roof corner bars (marked "R")

INSTRUCTIONS

1. Assemble the frame in exactly the same way as the rear end, up to and including stage 3 of the rear end. The difference with the door end is that instead of 1 long built in base piece, the door end has 2 smaller pieces (1 either side of the door opening) and 1 door end cill. The 2 vertical glazing bars are longer than the same bars used on the rear end assembly **(Key Point)**.

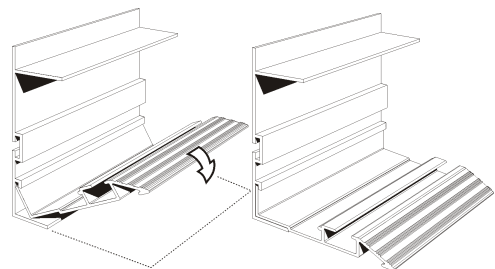

2. Now engage the door end cill with the 2 built in base pieces by pushing the angle of the cill under the locator as shown in the diagram. At this stage the cill will move freely left and right but will remain located to the built in base.

3. Slide 2 bolts into the bottom of each glazing bar and 3 bolts (only 1 if greenhouse to be sited on soft ground) into the free end of each built in base section. Attach the 2nd bolt in the glazing bar to the hole in the door end cill, but do not put a nut on yet. **Remember, the door end glazing bars are 95 mm longer than the rear end ones and do not sit on top of the base (as the rear end glazing bars do), they go down the side of the base and attached to the bottom cill. (Key Point)**.

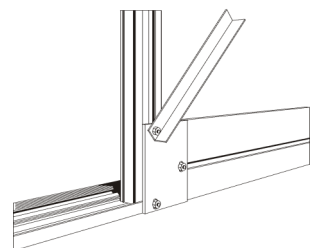

4. Attach the rectangular plate (with 3 elongated holes) to the 2 bolts inserted in the glazing bars and the last bolt inserted into the built in base ensuring that the glazing bar is tight down into the angle of the door end cill. Attach the diagonal angle to the top bolt of the rectangular plate. The 2 unoccupied bolts in the built in base sections will be used to anchor the greenhouse to the floor.

5. Attach the main door track support (shaped like a letter 'Z' to be found with the door panels) to the two bolts that secure the glazing bars to the corner bars. **(Key Point)**. This 'Z' shaped bar must be fitted with the two outside slots facing upwards (as illustrated) **not** downwards. The main door track support attaches to the upper bolt by going **between** the corner bar flange and the glazing bar. **(Key Point)**.

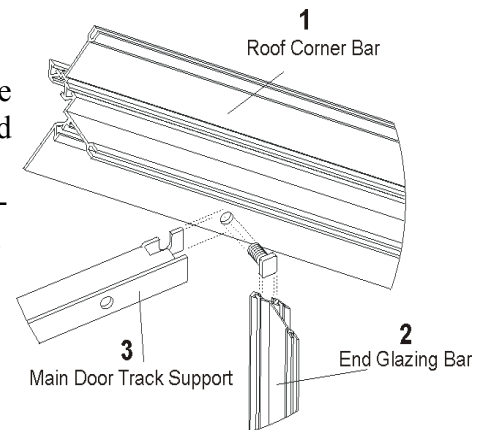

6. The two door end horizontal angles attach to the **top bolt** in the gusset plate and the vertical glazing bars.

7. Stand the frame up and bolt the door track to the main door track support and the small angle door track support by inserting 3 bolts into the bolt slot of the door track. Position 3 of these through the 3 holes in the door track support above the door opening. At this stage you do not need to adjust the track for level or square. This will be done later when fitting the doors.

8. Insert 2 extra bolts into each end of the door track which will be used later during general assembly.

9. When this has been achieved tighten all nuts.

10. Slide a bolt into the bolt slot in the built in base section, one at each end. Attach the corner bracket so that it is pointing downwards. If you are fitting your greenhouse onto soft ground, then do not fit the corner bracket yet. If you are on a patio, you will need to cut the corner bracket off level with the bottom of the built in base and slide extra bolts into the bolt channel to which will be attached the anchor brackets (generally 1 every 2'). If you are on soil, the corner bracket will go into the ground at general assembly.

N.B. Please note carefully the correct position of the main door support. The slotted holes at either end are facing skywards **NOT** downwards. **(Key Point)**.

DOOR END ASSEMBLY

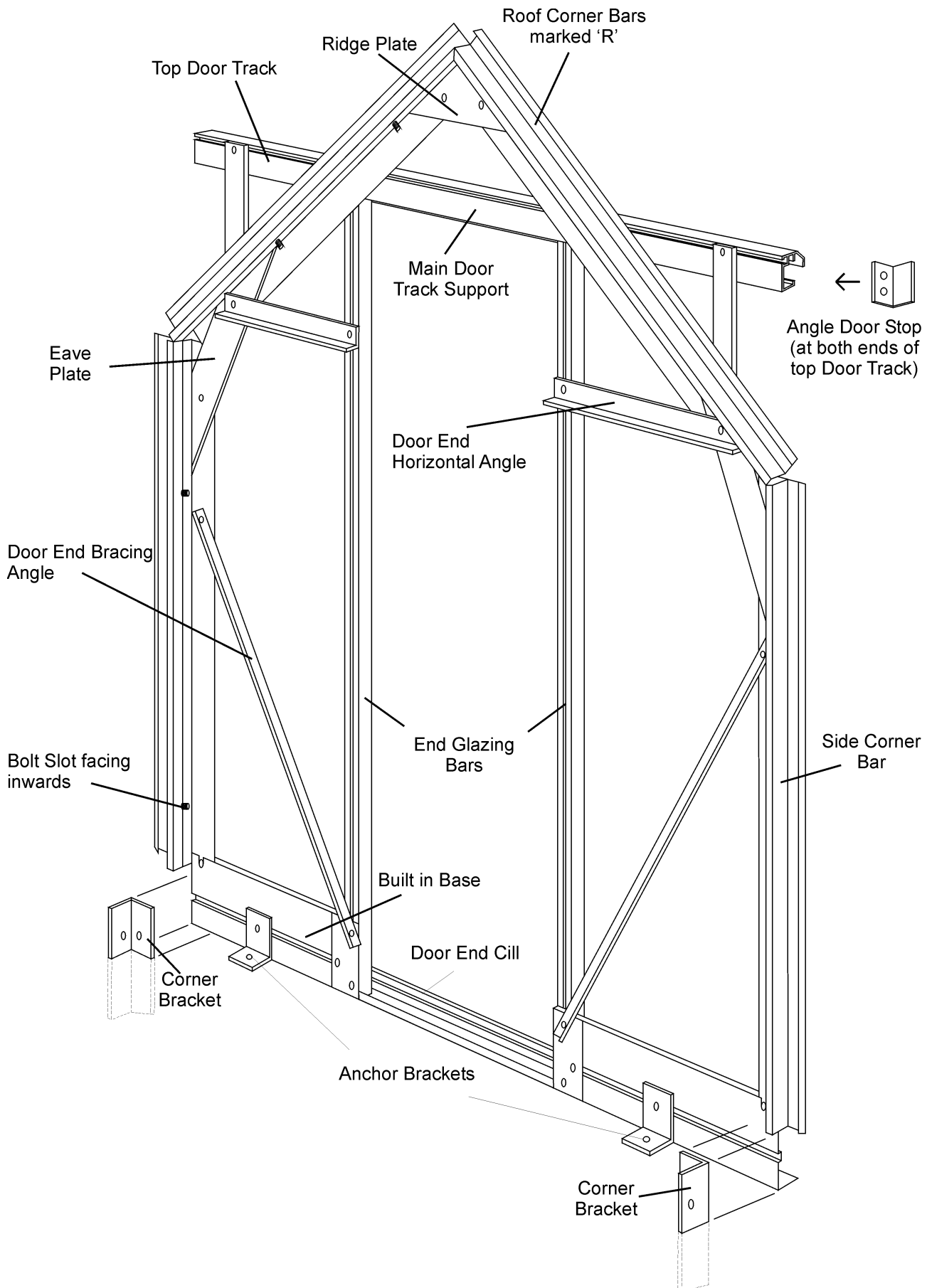

DOOR FRAME ASSEMBLY

Each Door consists of:

- 1 unhandled door post
- 1 handed door post (handed post for left door is different profile to the handed right hand door post)
- 3 infill panels (1 with pre fabricated lock hole) for lock barrel
- 1 top and bottom door panels
- 3 panels of glass which must be fitted during door assembly. **It is not possible to fit glass after the door is built**

From the main bag of fittings you require;

- 2 door wheels
- 1 clip on nylon door skid (this might already be fitted to the bottom door panel)
- 2 lengths of black brush draught excluder with PVC carrier
- Door lock, self tapping screws and spring washers
- 12' glazing beading
- Door handles
- 3 PVC Glass strips

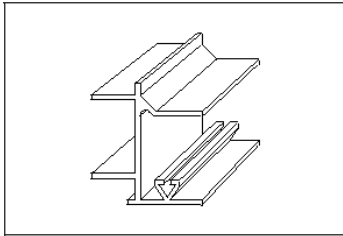

HANDED DOOR POST
RIGHT HAND DOOR

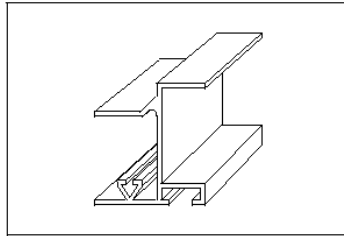

HANDED DOOR POST
LEFT HAND DOOR

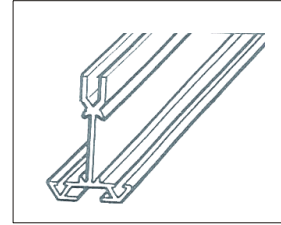

UNHANDLED
DOOR POST

Left hand Door (viewed from outside)

Identify the correct door posts. The handed door post for the left hand door has a bolt channel, whereas the handed door post for the right hand door post does not. **(Key point).**

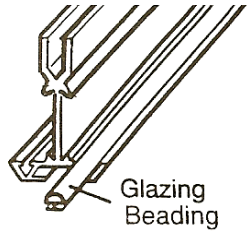
1. Place one unhandled post and the handed post for left hand door on a level surface roughly two feet apart with the bolt slots facing downwards. (Unhandled door post on the left, handed door post on the right). The top of each side post has two screw holes in it, the bottom has three. **(Key point).** Slide the glazing beading into the groove of each bar i.e. only one length of glazing beading per bar.
- 
- Glazing Beading
2. Place the top, bottom and 3 infill panels in position as shown by the position of the screw holes in the side pieces and the panels. The top panel has the greenhouse name on it. The bottom panel has the edge for the door skid to fit on. The lower infill panel locks on to the bottom panel. The infill panel for the left hand door **does not** have a pre fabricated hole for the lock barrel.
 3. Fix the left hand door post to the door panels by screwing through the door side pieces into the holes provided in the edge of the panels with the self tapping screws. The screws will go in more easily and with out danger of trying to go crooked if you can put a small amount of grease on the screw before assembling the doors. Alternatively, you could insert the screws into the screw eyes of the door panels before assembling the door; this would have the effect of pre-self tapping the panels prior to assembly, making assembly easier.
 4. **GLASS MUST BE FITTED TO EACH DOOR BEFORE THE 2ND DOOR POST IS FITTED—KEY POINT**

- Before fitting the unhandled door post, offer the glass panels to the door (see glazing plan in booklet for glass size guide on door), slide them in from the side. Carefully attach the unhandled door post in the same way as before, ensuring the glass is sitting in the correct position (sitting on the beading channels of the door posts) before tightening the screws.

- Make sure all angles are square and tighten all screws. Now insert 2 glazing clips to the glass on the unhandled door post.

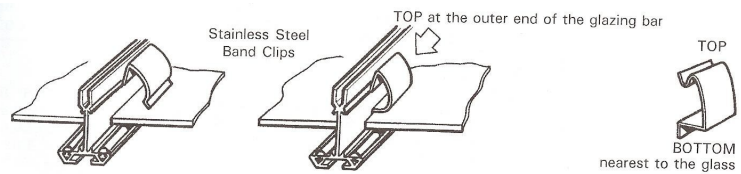

The other side of the door is clipped using a pvc glass strip (or clip cap). Cut the strip to the correct length and push into the cavity between the glass and the handed door post. The cap when fitted acts as a wedge to prevent movement of the glass. Metal clips are not fitted to this bar.

- Fix each door wheel into position by pushing the bolt provided through the centre of the wheel and then through the hole in the top door panel from underneath (i.e. from the inside of the door). Put the washer over the bolt and secure with the nut provided, tightening until there is no movement on the bolt. The nuts are lock-nuts and are harder to put on than normal nuts in general assembly. The wheel will revolve freely because it has ball bearings in it. **The wheel has a collar protruding from the centre, this collar goes against the inside face of the top door panel. (See picture below).**

- Slip the nylon door skids on each of the bottom panels. This may already have been done prior to delivery. After fitting the doors (see later in the booklet), you may need to lower the door skid so that it engages with the bottom door cill to allow smooth movement of the door. Lower the skid on each door and insert a self tapping screw at each end of the skid to reinforce the position.

- Build the right hand door using the remaining handed and unhandled door post. Viewed from the outside, the handed door post will be on the left of the door, while the unhandled door post will be on the right. At this point you must decide the height you would like your door lock. The hole to take the door lock is on the left hand side of the infill panel. You can decide to fit this panel to the 2nd or 3rd panel down. **Make sure you fit the glass before final fixing of the door.** See glazing plan towards the back of this booklet

- Thread the stainless steel backed brush extruder into the PVC carrier. This may already have been done prior to delivery

- Turn the doors over and insert the black brush draught excluder in the groove (bolt slot) in the unhandled door posts. Insert a nut and bolt at the bottom of each unhandled door post and tighten so that the brush will not slip down when the door is in its upright position, Cut off the surplus brush and carrier at the top of the bar

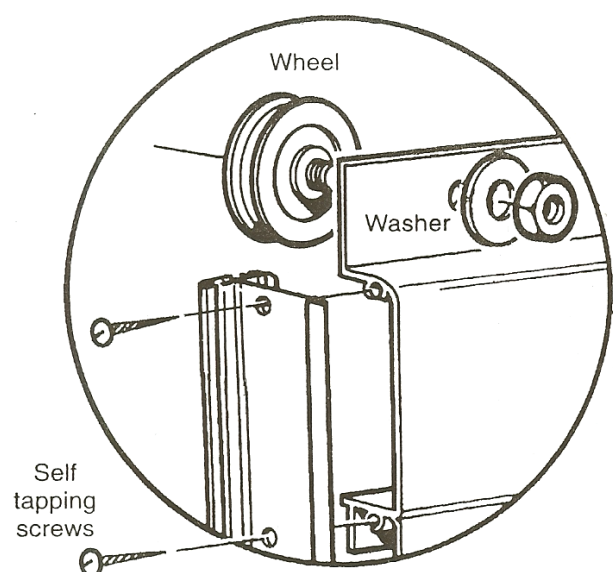

- Do not fit the door to the gable at this stage – wait until the structure is fully assembled prior to glazing.

- Door handles can now be fitted.

DOOR FRAME ASSEMBLY AMENDMENT

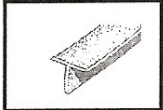

DRAUGHT EXCLUDER

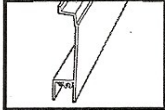

DOOR INFIL PANEL

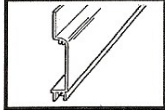

DOOR TOP/
BOTTOM PANEL

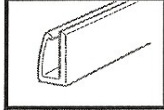

DOOR SKID

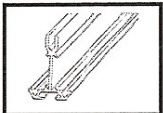

UNHANDLED
DOOR POST

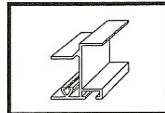

HANDED DOOR POST
LEFT HAND DOOR

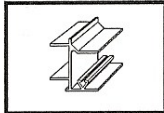

HANDED DOOR POST
RIGHT HAND DOOR

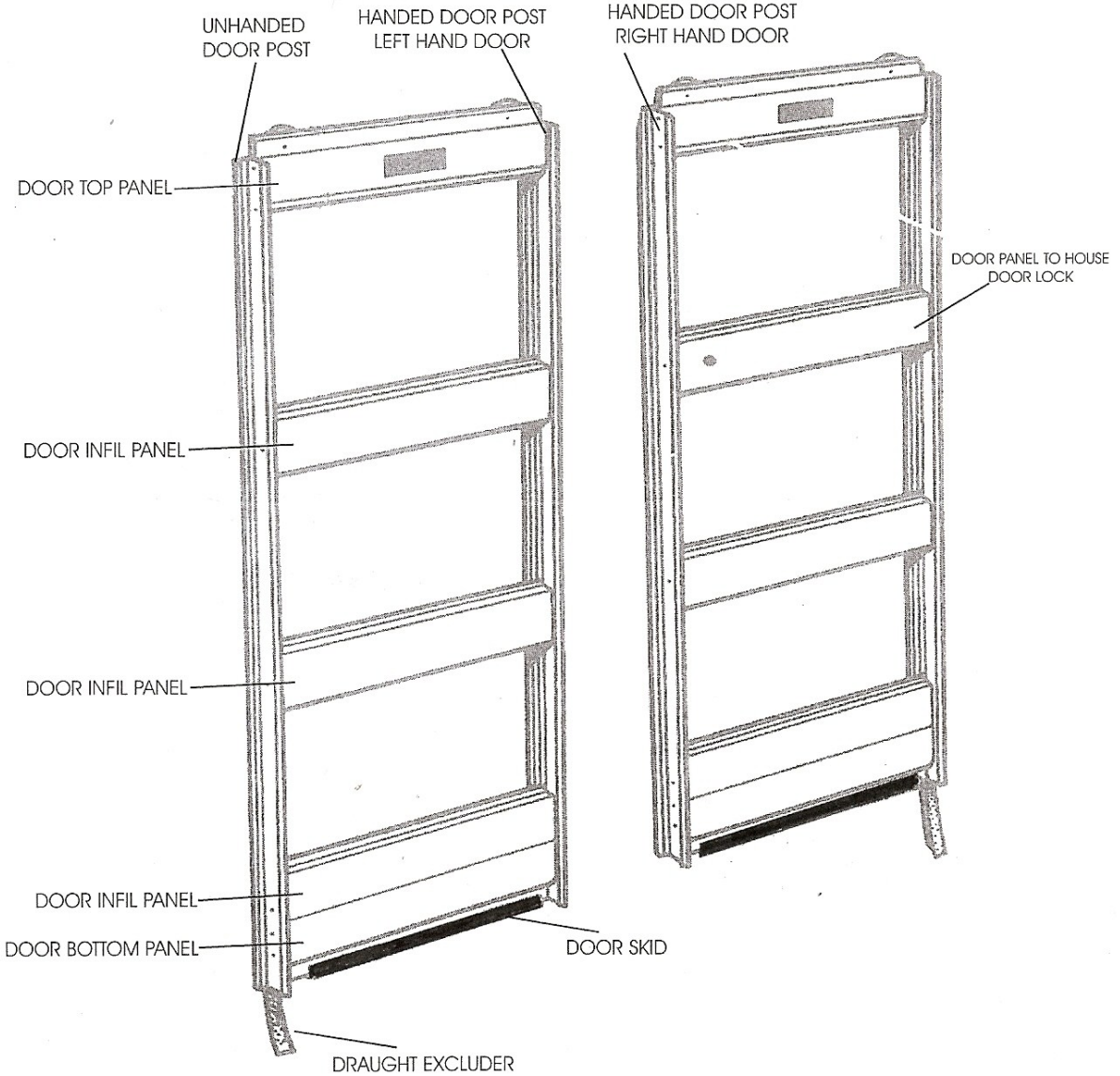

FITTING THE DOOR HANDLES

The handles are fitted to the infill panel on each door (choose between 1st or 2nd panel down). Position the handle centrally, and mark the hole position. Drill 7mm diameter holes (2 holes per door), then fit the handles, and secure with a nut and bolt.

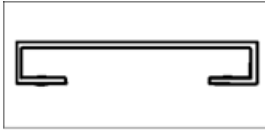

DOOR HANDLE

FITTING THE DOOR LOCK

The door lock must be fitted after the doors are in position (**Key Point**). Undo the ring bolt from the door lock, and insert the barrel through the hole in the panel from the outside. Reattach the ring bolt to the barrel on the inside, and tighten.

Now attach the cam lever, washer and screw to the door lock from the inside position of the door. The lock will turn through 90 degrees both ways, so you must ensure the cam (when fitted) is pointing skywards (unlock position) and horizontal (locked position)

Now using a cropped head bolt, attach the domed pin to the bolt channel of the handed door post on the left hand door (viewed from outside). Move the pin up or down in the channel so that the notch on the cam locates comfortably when horizontal. Tighten all components.

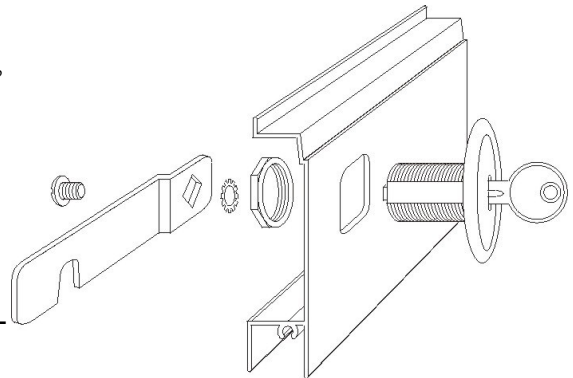

FINISHING OFF

To prevent the door from sliding past its opening, you must fix 2 angle brackets to the door end assembly.

Insert a cropped head bolt into the bolt channel at the top of the left hand glazing bar (viewed from the inside) and fix an angle bracket as shown in the picture below.

The bracket must be fitted at the same height as the door panel so that, as the door moves left or right, the bracket prevents the door from moving too far along the top door track.

Repeat at the bottom of the door

Repeat for the 2nd door

To facilitate smooth running of the door, fit 1 flat bar at each end of the top door track.

The flat bar has 2 holes of different size. Loosely fix the larger hole to the bolt channel at the back of the top door track using a short bolt and allow the flat bar to hang vertically down.

Move the flat bar along the top door track until the small hole in the flat bar meets the self tapping screw groove in the roof corner bar.

Fix the small hole in the flat bar to the corner bar using a self tapping screw.



ROOF VENT ASSEMBLY

The roof vent pack has 5 pieces of aluminium and from the main box of fittings you require:

- 6' of glazing beading
- 4 nuts and bolts
- 2 casement stay pins
- 1 casement stay
- 6 M4 stainless steel nuts and bolts

PROCEDURE:

1. Identify the slam bar and attach the 2 stay pins to the outer side of the angle using the M4 stainless steel nuts and bolts.
2. Lay the 4 edge pieces of the vent on a level surface as though you were on the inside of the vent (with the bolt slots of the vent side rail uppermost and the 'v' slots of the vent bottom rail uppermost). The vent top rail is arranged in such a way that the squared off end is to the bottom and the hooked hinge uppermost).
3. Slide the glazing beading into the slot in the vent side and top rails and trim to suit.
4. Insert a bolt into each end of the vent side rail bolt slots, put these bolts through the holes in the vent top and bottom rails, add nuts and lightly tighten. Check that all joints are secure and that the vent is square, then tighten up the nuts.
5. Fit the casement stay using the M4 stainless steel nuts and bolts, putting the bolts through the holes in the saddle of the stay through the 2 elongated holes in the vent bottom rail. Hold the nuts in place and tighten the bolts with a screwdriver.

Do the same with the other vents.

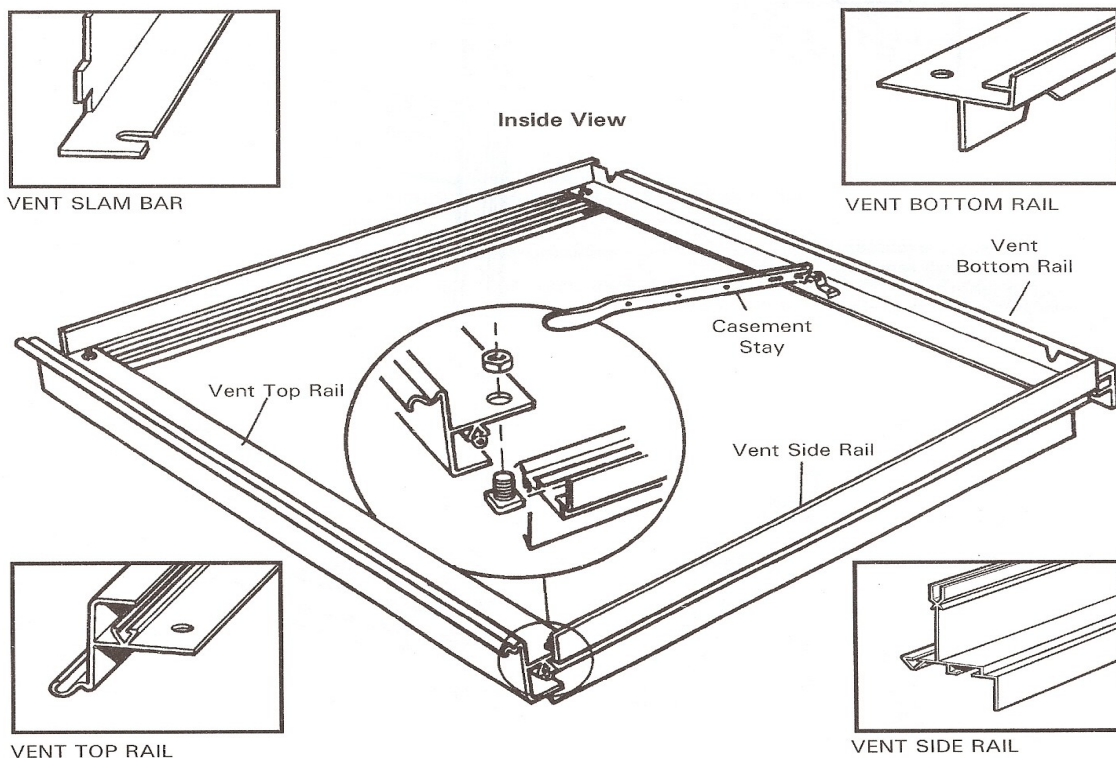

ASSEMBLY OF GREENHOUSE UNIT

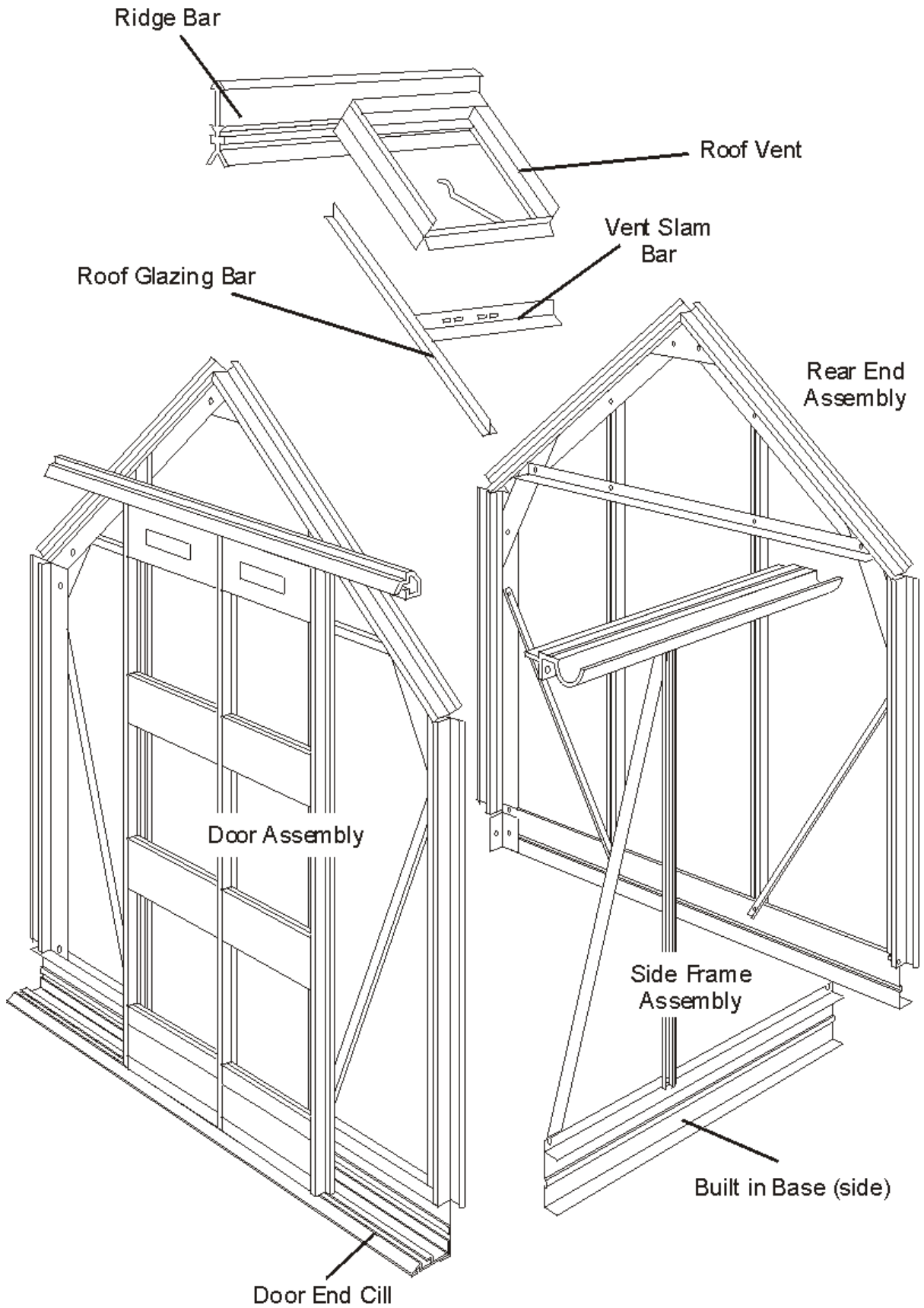

The first operation is to connect the two side frames to the end frames to form the outer shape of the completed structure. Another pair of willing hands would be useful at this stage.

1. Lift the first side frame into its position by the rear end.
2. Slot the eaves bar into the small space between the roof and side corner bar so that the gutter is outside the end frame and the two flanges that form the angle of the roof and side are inside and tight up against the bolt slots of the roof and side corner bar. **(Key Point)**.
3. The extra bolts that were inserted in the bolt slots during the gable end assembly can now be used.
4. Line up the elongated holes in the flanges of the eaves with the bolt slots and slide the bolts into them. Put nuts on and tighten up. **(Key Point)**.
5. The built in base attaches to the inside of the side corner bar. The bolt placed in the side corner bar bolt slot at gable end assembly will slide down into the slotted hole at the end of the built in base. Likewise with the corner bracket, this can now be attached to the end built in base utilising the bolts inserted at frame assembly.
6. Do the same at the other three corners.

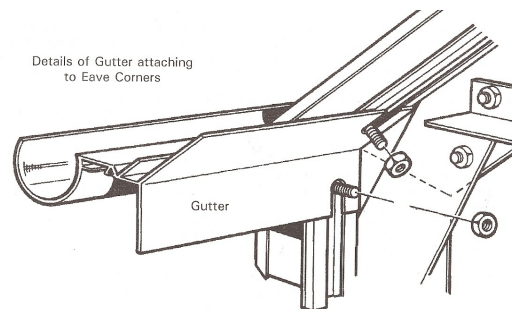

7. Slide the glazing beading into both sides of the ridge before attaching the ridge to the roof corner bars. Insert the end of the ridge through the small gap in the roof corner bars at the top, the vertical part of the ridge will be outside, pointing skywards and the two flanges that form the angle of the roof will be inside, tight up against the bolt slots of the roof corner bars.
8. Line up the slotted holes at the end of the ridge with the bolt slots in the roof corner bars. Push the two bolts, previously inserted during the gable end assembly into the slots. Put on nut and tighten.

9. The roof bars can now be attached to the ridge and gutter. Slide the glazing beading into the roof glazing bars first. There are two channels per bar that require beading but glazing beading is not required in the part of the glazing bar that goes under the vent. Attach them to the ridge first by sliding a bolt into the bolt slot of the glazing bar and inserting it through the hole in the flange of the ridge. Put a nut on and tighten up. Do the same with the rest of the roof bars.

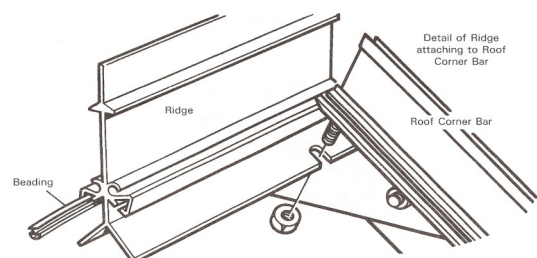

10. Before bolting the bottom of the roof bar to the flange of the eave bar, insert extra bolts. Where the roof vent is to be positioned put an extra one bolt per bar i.e. the roof vent covers two glazing bars so two extra bolts per vent. **(Key Point)**. Then attach the final nut and bolt to the eave bar as illustrated.

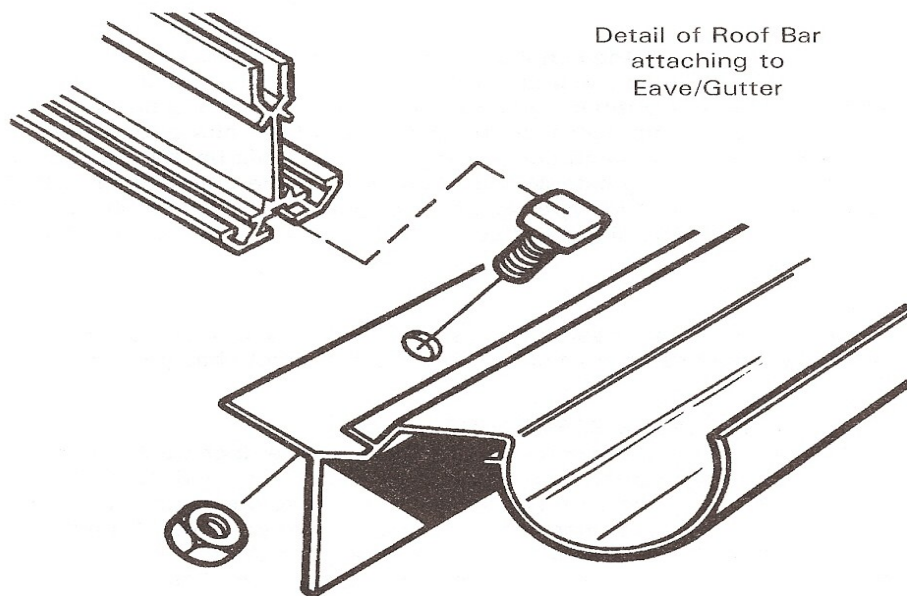

NOW YOU CAN FIT THE VENT TO THE RIDGE

11. Before sliding the vent into the ridge, slide a piece of black tube into the vent hinge socket. Slide the roof vent onto the ridge as indicated in the diagram below from either end and into the desired position. When the roof vent is in the correct position push the black tube up to the roof vent hinge, insert a small self tapping screw into the black tube approximately $\frac{1}{2}$ way along then tighten the screw. The tube will expand and lock into position thus preventing sideways movement of the roof vent. These are two tubes, one each side of the vent.

N.B. There is no hole for the screw but it will easily push into the black tube and screw up. **(Key Point)**. The roof vent overlaps the two glazing bars that it covers so is therefore wider than the opening. Having slid the roof vents from the end on the ridge to the desired position, you can now fit the “slam bars” to the 2 glazing bars. Utilise the bolts you inserted during general assembly and position the “slam bars” just under the roof vent allowing the casement stay to effectively close. The slam bar can be adjusted later to facilitate good opening and closing of the roof vent.

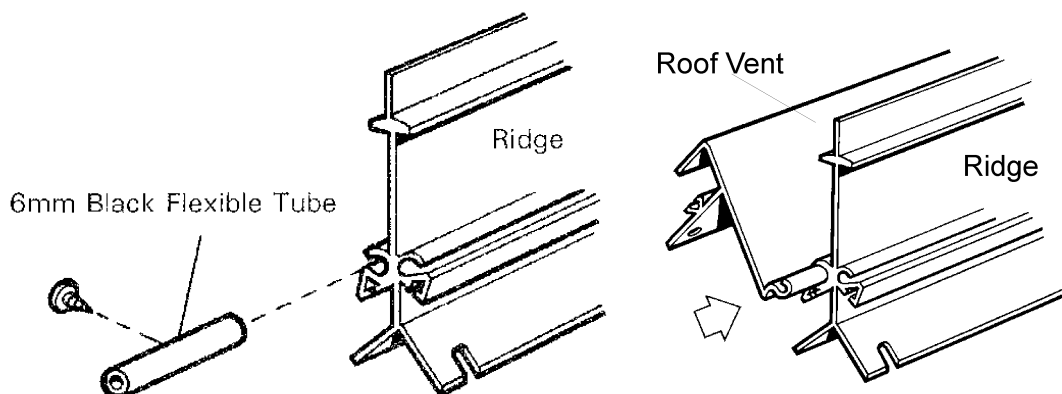

12. Do not fit the door at this stage.
13. The greenhouse is now ready for lifting on to its permanent base.
14. If you are fitting the greenhouse onto soft ground, you now need to dig 1 hole (approx. 1 spade width) in each of the 4 corners. You will also need some hard standing under the door end cill. A flag stone or a course of bricks immediately under the threshold or door way at floor level.
15. Lift the greenhouse into position. For soft ground fixing, you now need to attach the corner bracket to the bolt slot of the side and end using the end of the bracket that has 2 holes as opposed to 4. The bracket must be attached in such a way that the end with 4 holes is pointing down into the hole previously made.

SQUARING UP

You must make sure that the structure is level and square. Put one pane of glass in each corner of roof, each pane must be level with the small glass retaining lip just above the gutter and be running parallel with the roof glazing bars. Each corner must be the same. If one corner is out the corner diagonally opposite will also be out. By carefully pushing and pulling each corner diagonally you will be able to see the frame move in and out of square with the glass.

HARD STANDING

Having established the square of the greenhouse, drill the patio or concrete in the required positions, fit plastic plugs and screw the angle brackets (attached during sub-assembly) firmly to the ground using 35mm x 8mm round head screws and stainless steel washers.

SOIL FLOOR

Determine the square of the greenhouse as described above, make a mix of concrete and put a couple of shovelfuls around the base of each corner bracket. When the concrete has gone off back fill with the soil excavated earlier on.

FITTING THE DOORS TO THE STRUCTURE

The doors slide onto the frame from opposite sides of the door tracks. For the left hand door put the door bottom rail into the bottom door track and slide to the right, feed the first wheel into the top door track and move further to the right until the black draught excluder butts up to the end glazing bars. Carefully ease the door past the glazing bar and feed in the second wheel. Repeat the process for the right hand door. (Ensure handed door posts meet in the middle). The doors will now run quite freely. To square up the door with the spacing, undo the upper bolts holding the door track. There is a little play to facilitate "fine tuning" of the doors. N.B. Sometimes the doors can be a little stiff prior to glazing but once the glass has been inserted (the last job of the construction) the extra weight will make for smooth running.

There are two pieces of flat bar approximately 125mm long that act as small door track supports attached to the top door track either side of the door way. The end of the flat bar with the larger hole bolts to the back of the top door track, the other end will line up with the groove in the face of the corner bar where a small self tapping screw can be inserted to tighten the flat bar to give extra support.

FITTING THE RAMP

The final aluminium piece of the greenhouse is the door end ramp cill. The ramp is attached to the door end cill by engaging the nub of the door end cill to the 'C' groove of the ramp. The ramp is now rotated to horizontal. Drill a hole at each end approx. 20mm in from the end of the ramp and into the floor. Plug and screw.

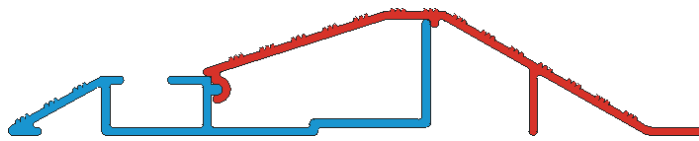

If you are fitting onto soft ground, you must ensure that a solid material is underneath the ramp to avoid damage when you step on the ramp to enter the greenhouse. You can lay a row of bricks sunk to ground level, a concrete flag, a piece of aluminium base pressed into the ground to ground level or something similar. You can then screw the ramp into the support material for a secure fixing.

GLAZING THE STRUCTURE

Always handle glass with extreme care as failure to do so can result in injury.

HORTICULTURAL AND MULTI-SHEET TOUGHENED GLASS

1. Starting with the bottom pane of one side, offer the pane to the glazing bars. Hold it in place by inserting two of the stainless steel clips six inches from the bottom of the glass. Fit the curved lip under the glazing bar and then rotate it so that the other lip clips over the edge of the glass. **(Key Point).**

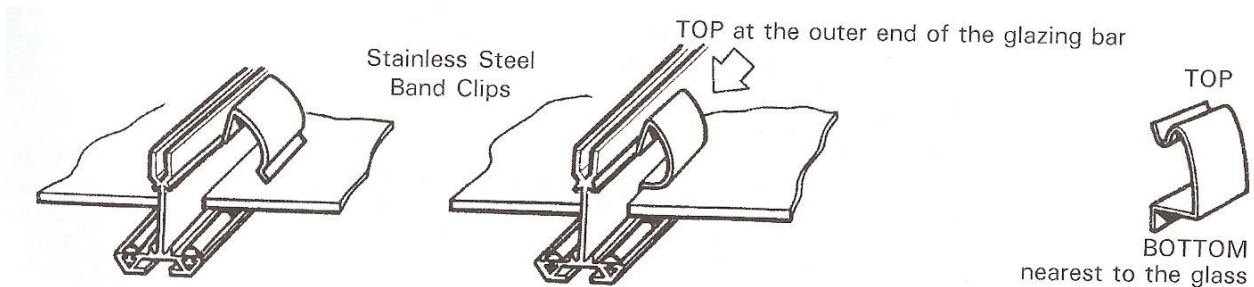

2. Secure the glass by inserting another two clips in the same way half an inch from the top edge of the glass. **N.B. The side panels will require a larger overlap of approx. 3/4" (20mm).**
3. Hook one overlap clip on the middle of the pane of glass. **(Key Point).**

4. Offer the next pane of glass to the glazing bars, resting it on the two clips of the bottom pane. Insert two clips to hold it six inches from the bottom of the pane. Bend the middle overlap clip upwards to support the glass. Secure the pane by inserting another two clips 1/2" inch from the top of the pane. Then put 1 overlap clip in the middle. Put the top pane of glass under the gutter, and then rest it on the 2 clips at the top of the middle pane. Now put 2 clips approx. 6" up from the bottom of the final piece of glass and 2 clips 4" from the top.

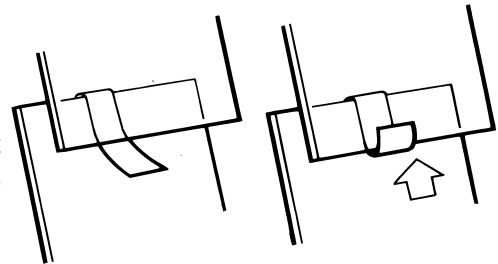

5. Repeat this all along this side of the house, then repeat it for the roof of this side (remembering that there are only 2 panes of glass in each roof section and only 1 overlap clip, but note that you have to use two of the stainless steel wire clips on the sides of the panes nearest to the roof vent so that the vent will close correctly. (See illustration for the correct way to fit these). **(Key Point).**

6. Repeat the glazing procedure on the other side of the house.

7. Following this, glaze the rear end in a similar fashion.

8. Proceed to the door end and glaze that, but use wire clips on the left hand edges of the panes to the right hand side of the door opening, so that the door slides open correctly. **(Key Point).**

9. Finally, glaze the door.

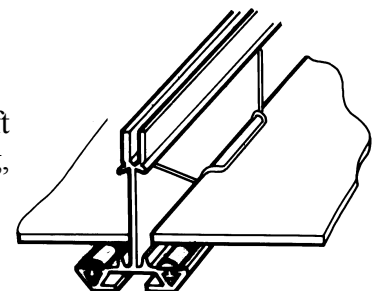

4' WIDE COMPACT HORTICULTURAL GLASS/ & MULTI-SHEET TOUGHENED GLASS PLAN

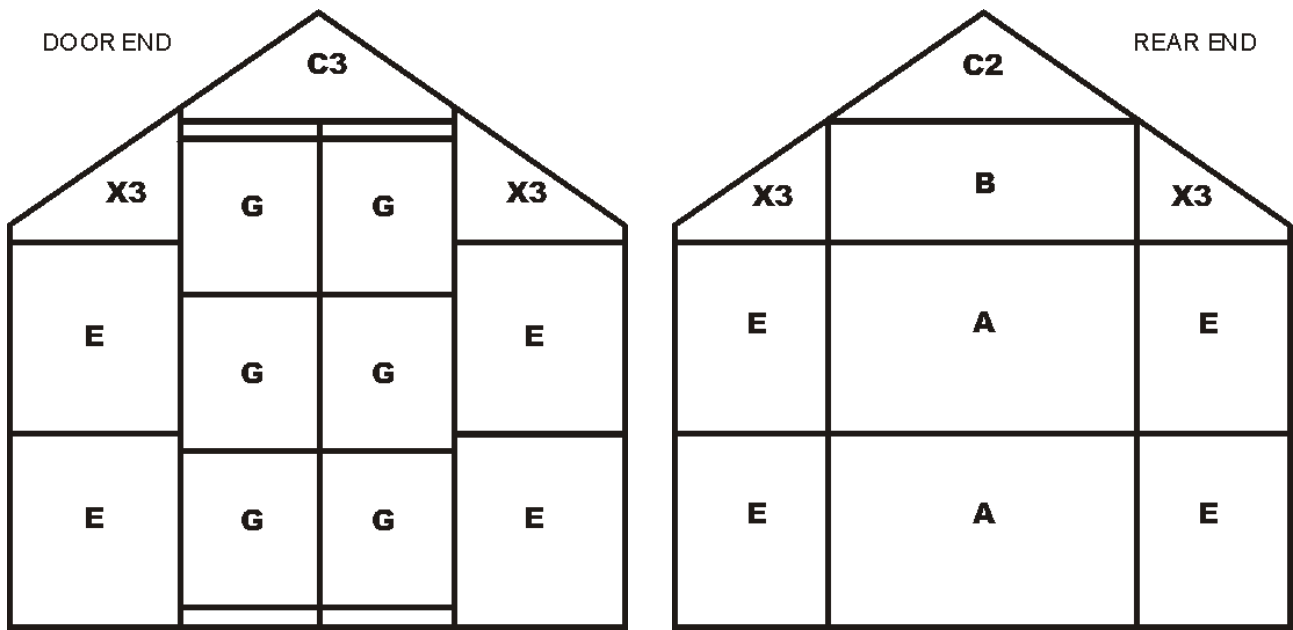

SIDE

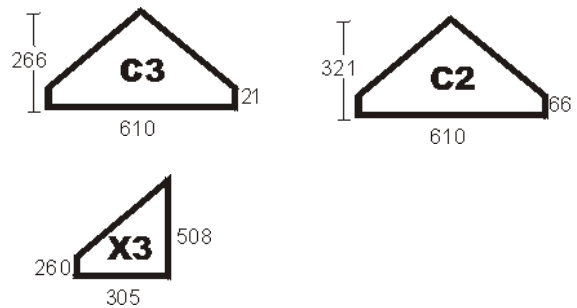
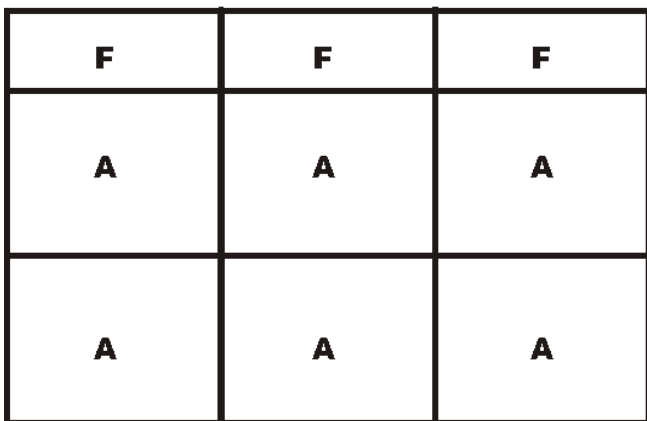

ROOF

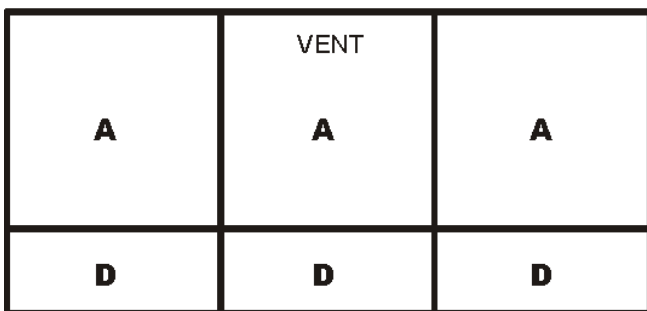

Ref	Width (mm)	Length (mm)
A	610	610
B	610	457
D	610	210
E	610	305
F	610	267
G	300	457

Ref Size	A	B	D	E	F	G	X3	C2	C3
4 X 4	14	1	4	8	4	6	4	1	1
6 X 4	20	1	6	8	6	6	4	1	1
8 X 4	26	1	8	8	8	6	4	1	1

If you install a louvre to the greenhouse, it (along with the 610 x 140mm piece of glass in the louvre box) replaces 1 A pane. You must ensure that you fit glass above and below the louvre. The louvre can not sit directly on the bottom aluminium cill. **(Key Point).**

FULL SHEET TOUGHENED GLASS (EN12150).

If you have purchased bar capping as an optional extra, see separate instructions with the capping for fitting instructions.

The main differences in application between the two types of glazing are:

1. Toughened glass is in large sheets.
2. There are no overlaps: where there are two or more panes in a section they are butt jointed with a P.V.C. overlap strip – (called a muntin) – **you do not use muntins if you have multi-sheet (or small pane) toughened glass.**
3. See the diagram for the position of the different sizes.
4. The glass is clipped onto the frame in the same way as the horticultural glass is, but use 8 clips per large pane.
5. Put the P.V.C. overlap piece (muntin) on top of the lower pane making sure you have differentiated between the inside and outside of the P.V.C. (see diagram below). The next pane sits on top of the overlap and is clipped in as normal.

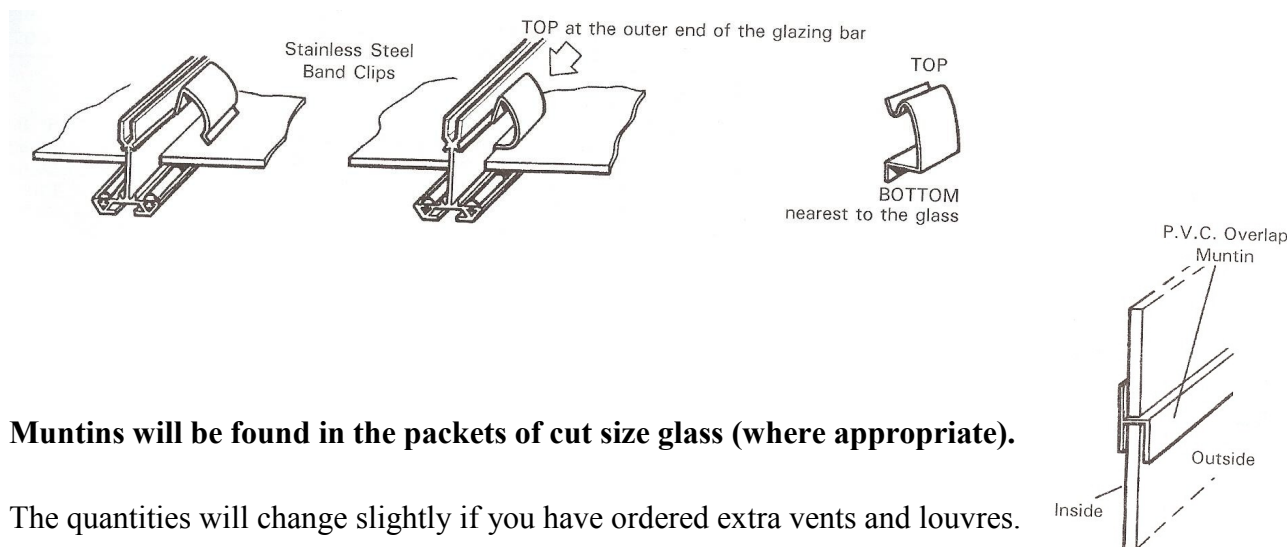

Muntins will be found in the packets of cut size glass (where appropriate).

The quantities will change slightly if you have ordered extra vents and louvres.

If you intend to fit a louvre to the greenhouse you must fit glass above and below the louvre. The louvre cannot fit onto the bottom aluminium cill. **(Key Point).**

Louvre Rear Fitting

Replace pane '9' with 1 piece 610 x 140 (found in louvre box with louvre frame), the louvre and then 1 ref 18.

Louvre Side Fitting

Replace pane '23' with 1 piece 610 x 399 (packed with glass shapes), the louvre and then pane ref '18'.

Elite will automatically assume that you wish to fit the louvre in the rear gable unless you have specified differently at the time of order.

4' WIDE COMPACT FULL SHEET TOUGHENED GLASS PLAN

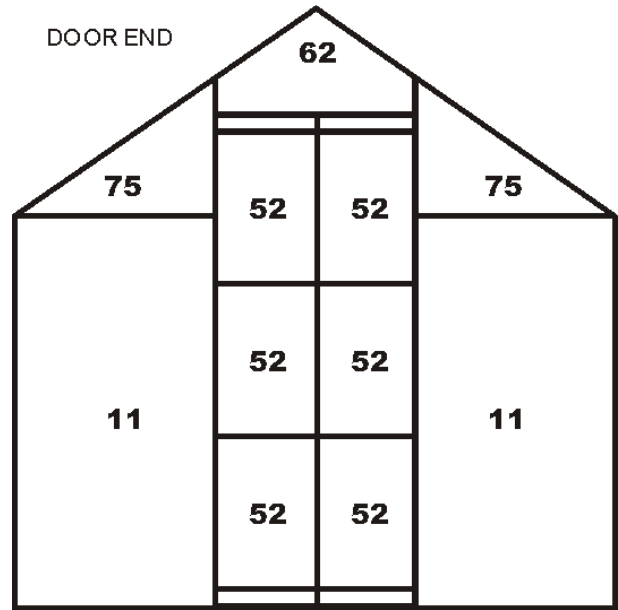
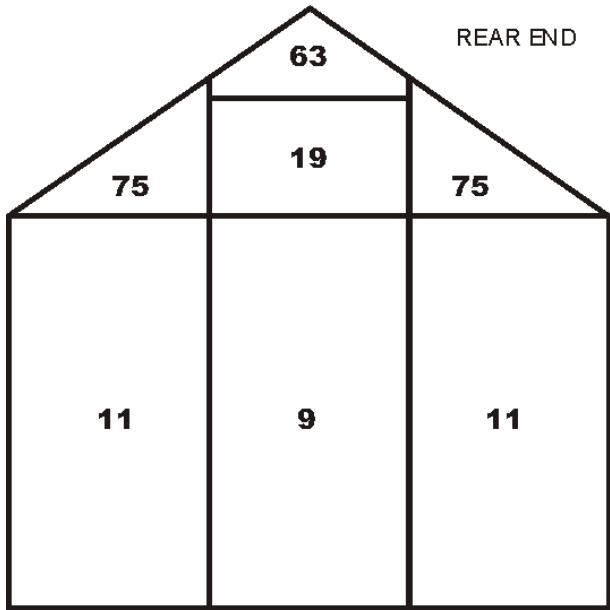

ROOF

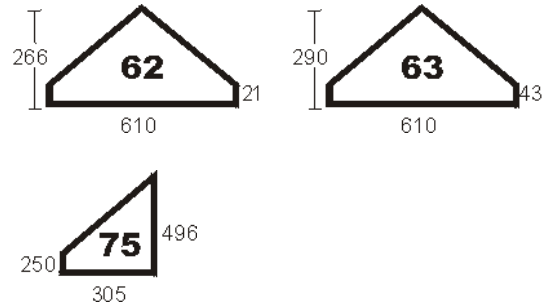
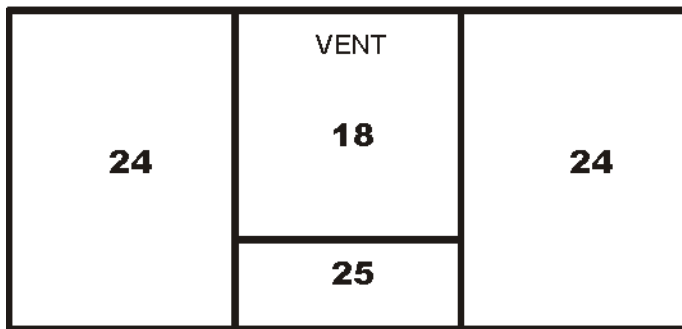

SIDE

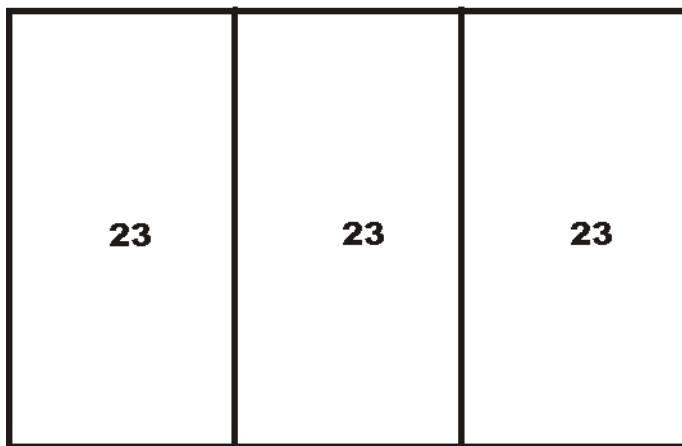

Code	Width (mm)	Length (mm)
9	610	1197
11	305	1197
18	610	610
19	610	457
23	610	1456
24	610	803
25	610	210
52	298	457

Ref Size;	9	11	18	19	23	24	25	52	62	63	75
4 x 4	1	4	1	1	4	3	1	6	1	1	4
6 x 4	1	4	1	1	6	5	1	6	1	1	4
8 x 4	1	4	1	1	8	7	1	6	1	1	4

YOUR GREENHOUSE IS NOW COMPLETE.

ELITE 1403